



종합환경장비

고압 세척기 · 고압펌프 · 청소장비 · 셀프 세차용품



(주)크린피아
1600-5335

비 전

지속적인 혁신을 통하여
회사의 가치를 높이며
고객과 사회로부터 신뢰받고
서로의 행복을 도와주며
사회에 봉사하는 회사

목 차

■ 크란즐 고압 세척기	3
· 소형 고압세척기	
· 냉수 단상 고압세척기	
· 냉수 삼상 고압세척기	
· 냉·온수 고압세척기	
· 엔진형 고압세척기	
■ 이태리 냉·온수 고압 세척기	8
■ 제작형 고압 세척기	9
■ 고압 펌프 및 모터	14
· 아노비 펌프	
· 인터펌프	
· 우도, 호크펌프	
· 라벨모터	
■ 고압 펌프용 약세사리	25
■ 크란즐 전용 약세사리	34
■ 크란즐 전용 수리부품	35
■ 쿨미스트 펌프 및 약세사리	37
■ 다이어프램 펌프	38
■ 셀프 세차용품	41
■ 노즐 도표	43



NEW K 1050P (가정용)



- 용도
- 간단한 세차
 - 고급형 자전거 및 바이크 관리용
 - 마당 청소
 - 외벽 청소
 - 전원주택 관리용
 - 직수 사용 (자흡 불가능)



대리석 바닥 청소



바닥 청소

HD 7/122TS



- 용도
- 운동화 세척(빨래방 전용)
 - 에어컨 실외기 청소용
- * 옵션 : 근거리용 짧은 건으로 교체 가능



화장실 청소



자전거 청소

K 1122TST



- 크고 일체화 된 바퀴와 충분한 길이의 전원선(5m)
- 용도별 선택 사용이 가능한 회전 및 가변노즐
- 랜스 및 건 수납공간
- 필터가 장착된 세계 흡입장치



운동화 세척



울타리 청소



카펫 세척



차량 휠 청소



위터 미스트 분사



외벽 청소

● 특징

1. 핸디형, 컴팩트한 디자인
2. 저소음 모터 및 자동 정지 기능
3. 황동 펌프헤드 및 세라믹 코팅 피스톤
4. 안전 사용 및 누수방지 시스템
5. 안전장치가 구비된 분사 건
6. 연속적인 압력조절 가능 (HD7/122TS, K1122TST) *K1050 압력조절불가능

● 사양

주문번호	모델	압력(Bar)		토출량 (ℓ/min)	전원	분사 노즐	바리오노즐 회전노즐	무게 (kg)	고압호스 (m)	자동 정지	소음도 (dB)	크기(mm) (L×W×H)
		최대허용	상용									
CLP32101	K 1050P	160	130	7.5	단상 220V, 2.2hp	03	선택사양	19	8	○	86	390×290×370
CLP42406	HD7 / 122TS	135	120	7	단상 220V, 1.3hp	028	선택사양	22	10	○	84	440×200×330
CLP42402	K 1122 TST	140	120	7.5	단상 220V, 1.6hp	03	○	31.5	릴 15	○	84	360×365×870

※ 내구성 향상을 위한 국내 최저 r.p.m 실현 (*K1050 제외)
 ※ 안전성 확보를 위한 국내 최고 모터보호등급 : IP 55

※자동 타입의 경우 건(손잡이)을 놓았을 때 작동을 자동으로 정지합니다.



K 2000 시리즈 (일반형)



Profi 시리즈 (산업용)



※ 국내에서 가장 많이 보급된 고압세척기



바닥청소 (계단)



바닥청소 (에폭시)



차량세차



대리석 바닥 청소



옥상 방수



바닥 청소



산업자재 청소



산업현장 바닥청소



바닥 청소(실외)



작업장 청소

● 특 징

1. 펌프 중심부의 제품 내구성 증가
2. 미래지향적, 인체공학적인 일체형 및 개방형 디자인
3. 물탱크 장착으로 공동화 방지 및 고압 세제 분사 (Profi)
4. 더욱 커진 바퀴로 인한 손쉬운 이동, 커진 고압 호스릴
5. 안전장치를 갖춘 분사건과 각종 노즐(회전, 분사)의 수납공간
6. 에너지 절약 및 기기 보호를 위한 자동정지(Total stop) 기능
7. 연속적인 제어가 가능한 압력조절밸브
8. 내부식성 황동 펌프헤드 및 내마모성 세라믹 피스톤 사용
9. 충격에 강한 내충격성 재질의 일체형 강화플라스틱 케이스 사용

● 사 양

주문번호	모 델	압 력(Bar)		토출량 (ℓ / min)	전 원	바리오 노즐	회전 노즐	무게 (kg)	고압호스 (m)	자동 정지	소음도 (dB)	물탱크	크기(mm) (L×W×H)
		최대허용	상용										
CLP55981	K 2160TST	160	140	11	단상 220V, 3hp	○	○	39.5	릴 15	○	78	X	375×360×900
CLP55982	K 2195TST	195	180	8	단상 220V, 3hp	○	○	39.5	릴 15	○	81	X	375×360×900
CLP92301	Profi 160TST	160	140	11	단상 220V, 3hp	○	○	45	릴 15	○	78	○	355×375×980
CLP92302	Profi 195TST	195	175	7.5	단상 220V, 3hp	분사노즐	○	45	릴 15	○	81	○	355×375×980

※ 내구성 향상을 위한 국내 최저 r.p.m 실현
 ※ 안전성 확보를 위한 국내 최고 모터보호등급 : IP 55

※자동 타입의 경우 건(손잡이)을 놓았을 때 작동을 자동으로 정지합니다.



Quadro 시리즈

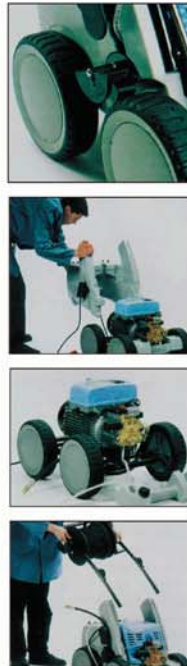

Bully 980 TS (보급형)



수영장 청소



농기계 세척



양식장 청소



차량 세척



중장비 세척



축사 청소



위터파크 청소



공원 청소

● 특 징

1. Auto Delay Stop/Start(30초)/모터보호기능: 건에서 물이 분사되지 않을 경우 30초 후에 모터가 정지되며, 건 레버 동작시 다시 가동
2. 20분간 사용하지 않는 경우 완전 정지되는 안전기능
3. 호스릴 장착 - 사용 후 호스 정리가 편함
4. 고압 터보노즐 (최고 320bar) 기본장착 (Bully 제외)
5. 분사 랜스와 이동이 용이한 대형 바퀴 기본장착
6. 세련된 디자인과 견고한 커버
7. 에너지 절약 및 기기 보호를 위한 자동정지 기능 (Total Stop)
8. 물탱크 용량 16L (Bully 제외)
9. 회전 분사노즐과 랜스 간의 간편한 퀵 커플링 방식 (Bully)

● 사양

주문번호	모 델	압 력 (Bar)		토출량 (l/min)	전 원	분사 노즐	터보 노즐	무게 (kg)	고압호스 (m)	자동 정지	물탱크	크기(mm) (L×W×H)
		최대허용	상용									
CLP62164	Quadro 700 TST	190	170	13	단상 220V, 5.5hp	○	○	89	릴 20	○	○	770×570×990
CLP62161	Quadro 800 TST	270	250	13.3	삼상 220/380/440V, 7.5hp	○	○	89	릴 20	○	○	770×570×990
CLP62162	Quadro 1000 TST	250	220	16	삼상 220/380/440V, 7.5hp	○	○	89	릴 20	○	○	770×570×990
CLP62173	Quadro 1200 TST	200	180	19	삼상 220/380/440V, 7.5hp	○	○	89	릴 20	○	○	770×570×990
CLP62181	Bully 980 TS	220	200	16	삼상 220/380/440V, 6.7hp	○	회전노즐	65	10	○	X	730×425×970

※ 내구성 향상을 위한 국내 최저 r.p.m 실현
 ※ 안전성 확보를 위한 국내 최고 모터보호등급 : IP 55

※ 자동 타입의 경우 건(손잡이)을 놓았을 때 작동을 자동으로 정지합니다.



Therm 시리즈

※호스릴 추가구매 가능



소방차 세척



버스 세척



특수장비 세척



축사 청소

● 특 징

1. Auto Delay Stop/Start(30초)/모터보호기능
2. 20분간 사용하지 않는 경우 완전 정지되는 안전기능
3. 불완전 연소 방지를 위한 Delay (0.5초) 점화방식
4. 보다 뛰어난 내구성 및 저소음
5. 고압세척 분사 가능, 세척 직접 흡입으로 분사에너지 효율증가
6. 이상고압 발생시 안전밸브 작동 장치 기계내부 기본장착
7. 물주입이 안될 때 보일러 작동 방지장치 내장
8. 스팀 분사 가능
9. 이상 고온 및 연료 부족시 버너 자동정지 기능
10. 버너 오작동 감지를 위한 광염 모니터링 장치
11. 안전밸브 일체형 유체 흐름 감지센서
12. 보일러 온도 조절 및 버너 성능
13. 펌프 및 버너 동작시간 표시 기능
14. 대형 연료 탱크 (35ℓ)
15. IF 디자인상 수상 모델

● 사 양

주문번호	모 델	압 력(Bar)		토출량 (ℓ/min)	전 원	보일러 최고온도	연료	연료 소모량 (kg/h)	자동 정지	연료탱크 (ℓ)	분사 노즐	무게 (kg)	크기(mm) (L×W×H)
		최대허용	상용										
CLP75303	Therm 640	145	130	10.6	단상 220V, 3hp	150℃	경유	4.4	○	35	○	200	1,050×800×1,000
CLP75302	Therm 900	210	190	15	삼상 220/380/440V, 7.5hp	155℃	경유	5.1	○	35	○	220	1,050×800×1,000

※ 내구성 향상을 위한 국내 최저 r.p.m 실현
 ※ 안전성 확보를 위한 국내 최고 모터보호등급 : IP 55

※자동 타입의 경우 건(손잡이)을 놓았을 때 작동을 자동으로 정지합니다.



B 170 T



● 특 징

1. 간편한 구조로 잔 고장이 없음
2. 가벼운 무게로 이동이 편리함
3. 폭이 넓고 견고한 손잡이
4. 고압호스릴 장착
5. 충격 흡수 완충 장치
6. 주차 브레이크
7. 유로 Honda 엔진 장착
8. 저 RPM: 1800rpm

● 용 도

1. 건설현장의 중장비 세척
2. 건물, APT 준공 전 잔여 시멘트 제거
3. 샌드브라스트를 이용한 녹 제거
4. 저수조, 상수도, 배수지, 탱크 세척 작업
5. 전기가 공급되지 않는 현장 작업
6. 이동이 빈번한 장소
7. 건물 외벽 페인트 제거
8. 건물 방수전 수세용도
9. 해안가 가두리 양식장 그물 해초 제거, 따개비 제거용도



중장비 세척



가두리 양식장 세척



특수 차량 세척



선박 세척



건설현장 세척



자재 세척



바위 이끼 청소



도장면 세척

● 사양

주문번호	모 델	압 력(Bar)		토출량 (ℓ/min)	소 요 동 력	연료	연료탱크 (ℓ)	분사 노즐	터보 노즐	무게 (kg)	크기(mm) (L×W×H)
		최대허용	상용								
411901	B170T (엔진형)	170	150	13	혼다 GX160LX	휘발유	3.1	○	○	68	710×560×1,000

인터펌프 냉수 고압세척기



TSX-951

특징

1. 잔고장 없는 간단한구조
2. 압력조절이 간편하고 조작이 편리
3. 가벼운 재질로 구성되어 이동이 편리
4. 타사 제품과 부품 호환이 가능함

용도

1. 건설현장, 음식료 공정 제품 및 각종 탱크드럼 내·외부 세척
2. 상·하수 사업소, 폐기물 사업소, 이물질 제거 및 필터 세척
3. 물탱크, 저수조 세척 및 농·수·축산물 관리시설 세척
4. 부두, 선박 수리소, 양식장 벽면, 그물 세척

테크노맥 냉·온수 고압세척기 시리즈



Kappa 110 / Kappa 170
(건-RL26)



Poker 200
(건-RL30)



Symbol 200
(건-RL30)



Symbol Silver
(건-RL30)

특징

1. Auto Delay Stop/Start (Poker, Symbol)
2. 간편한 내부구조와 컴팩트한 설계
3. 높은 열효율 및 불안전 연소방지를 위한 3초 Delay 점화
4. 연료펌프 고장 방지를 위한 Filter 장착

용도

1. 음식료 공장 살균세척 (탱크, 메쉬콘베어, 기계, 박스 등의 기름때, 찌든때제거)
2. 화학 반응조 수지제거, 주정공장 살균소독
3. 농·축산 사육, 가공, 도정공장 살균세척
4. 중장비 정비업소 기계 기름때, 찌든때 제거



찌든때 제거



도정공장 세척



세차장 세척



기름때 제거

사양

주문번호	모 델	압 력(Bar)		토출량 (ℓ /min)	전 원	자동 정지	무게 (kg)	고압호스 (m)	크기(mm) (L×W×H)
		최대허용	상용						
TSX951	TSX-951	150	130	11.3	단상220V, 4hp	○	33	8	650×500×950

사양

주문번호	모 델	압 력(Bar)		토출량 (ℓ /min)	전 원	보일러 최고온도	연료	연료 소모량 (kg/h)	자동 정지	무게 (kg)	고압호스 (m)	분사 노즐	크기(mm) (L×W×H)
		최대허용	상용										
TMKE110-11C	Kappa 110	110	100	11	단상220V, 3hp	120℃	경유	4	X	115	10	○	850×610×770
TMKE170-13C	Kappa 170	170	150	13	삼상220/380V, 5.5hp	120℃	경유	4	X	115	10	○	850×610×770
TMPK200-15	Poker 200	200	180	15	삼상220/380V, 7.5hp	140℃	경유	6.5	○	145	10	○	940×610×880
TMSYMA200-15	Symbol 200	200	180	15	삼상220/380V, 7.5hp	140℃	경유	6.5	○	165	10	○	940×580×880
TMSYSA200-21	Symbol Silver	200	180	21	삼상220/380V, 7.5hp	140℃	경유	7.8	○	195	10	○	940×580×880



모터형 냉수 고압세척기



CP200



CP275 / CP230



CP300 / CP350



CP500

특징

1. 프레임 재질이 스테인레스 및 잔닐로 되어 있어 내구성이 우수하며 잔고장이 없고 튼튼함
2. 기계에 적합한 재료를 사용함으로 가격이 저렴
3. 산업현장에 적합하도록 주문 제작이 가능함
4. 자동 정지 (Auto Stop) 기능 (선택사양)

용도

1. 건설현장 시멘트, 철구조물 등 녹, 페인트 제거
2. 수리 조선소, 외판 세척 및 페인트 제거, 신조 외판 세척
3. 석유화학 공장 탱크 크리닝, 열교환기 크리닝
4. 기타 산업현장, 건설현장, 특수산업 현장 청소 작업



공사현장 (세륜장)



녹 제거



건물외벽 세척

사양 ※호스릴 추가구매 가능

주문번호	모 델	압 력 (Bar)		토출량 (ℓ / min)	전 원	모터용량 (hp)	고압호스 (m)	분사 or 적사노즐	무 게 (kg)	크기 (mm) (L×W×H)
		최대허용	상용							
CP075A20RKA15	CP200	220	200	15	삼상 220/380V 60Hz, 5.6kw	7.5	10	O	52	900X500X750
CP075A20RKA15-A	CP200 (AUTO STOP 부식)									
CP075AI20W15	CP200									
CP075AI20W15-A	CP200 (AUTO STOP 부식)	230	200	30	삼상 220,380V/60Hz	15	10	O	84	900X500X750
CP150A20XWA30	CP230									
CP150A20RWA21	CP250	250	250	21	삼상 220/380V 60Hz	15	10	O	84	900X500X750
CP100A27RKA15	CP275	275	250	15	삼상 220/380V 60Hz	10	10	O	84	900X500X750
CP150A30SXW21	CP300	300	280	21	삼상 220/380V 60Hz	15	10	O	95	1000X580X890
CP200A35SXW21	CP350	350	300	21	삼상 220/380V 60Hz	20	10	O	95	1000X580X890
CP400A50RTP30	CP500	500	480	30	삼상 220/380V or 440V 60Hz	40	10	O	320	1,300X850X1,100

※ 440V 이상 전원장치 및 자동타입으로 주문할 경우 추가비용이 발생할 수 있습니다.

※ 상기 사양과 디자인은 사전 예고 없이 변경될 수 있습니다.

엔진형 냉수 고압세척기



+



호스 + 건 세트

CPE-150



+



호스 + 건 세트

CPE-250



+



호스 + 건 세트

CPE-250 SUS



+



호스 + 건 세트

CPE-350

특징

1. 잔고장 없는 엔진 사용
2. 간편한 구조로 잔고장이 없고 가벼워서 이동이 간편함
3. 간편한 압력 조절
4. 전기 사용이 곤란한 경우 어디서나 사용가능

용도

1. 건설 현장의 중장비 세척, 시멘트 제거, 녹 및 페인트 제거
2. 저수조, 상수도, 배수지, 탱크 세척 작업
3. 전기가 공급되지 않는 현장 작업 및 이동이 빈번한 장소
4. 해안가 가두리 양식장 그물 해초 제거 및 따개비 제거용
5. 침수나 홍수시 진흙 제거, 잔수처리
6. 과수나무 조피작업용



나무껍질 박피



식품공장 청소



돈사 소독 및 세척

사양 ※호스릴 추가구매 가능

주문 번호	모델	압력 (Bar)		토출량 (l/min)	엔진	KEY 시동방식	무게 (kg)	고압호스 (m)	분사 노즐	회전노즐	크기 (mm) (L×W×H)
		최대허용	상용								
CPEH065A15XMA13S	CPE-150	150	130	13	혼다6.5ps	X	26	10	O	선택사항	400X760X490
CPEH065A15XMA13L											
CPEH130A20RWA21S	CPE-200	220	200	21	HONDA GX390	O	70	10	O	선택사항	700X650X1000
CPEH130A25RKV15S	CPE-250	275	250	15	MX400	O	70	10	O	선택사항	700X650X1000
CPEH130A25RKV15L											
CPEH250A35SXW21	CPE-350	370	350	21	YAMAHA EH72	O	70	10	O	선택사항	700X650X1000
CPEY140A25RKV15L											
CPEY140A25RKV15S											
CPEY250A35SXW21											

※ 상기 사양과 디자인은 사전 예고 없이 변경될 수 있습니다. ※ 500bar 이상 (엔진형 사양 포함)은 현장별로 맞춤 주문 제작 가능

엔진형 냉수 고압세척기



+



CPE 150Z (수동)



+



CPE 150Z (자동)



+



CPE 275Z (자동)



● 특 징

1. 저가형 모델
2. 간편한 압력 조절
3. 전기 사용이 곤란한 경우 어디서나 사용가능

● 용 도

1. 건설현장 시멘트, 철구조물 등 녹, 페인트 제거
2. 수리 조선소, 외판 세척 및 페인트 제거, 신조 외판 세척
3. 석유화학 공장 탱크 크리닝, 열교환기 크리닝
4. 기타 산업현장, 건설현장, 특수산업 현장 청소 작업

● 사 양 ※호스릴 추가구매 가능

주문번호	모 델	압 력(Bar)		토출량 (ℓ/min)	엔 진	KEY 시동방식	무 게 (kg)	고압호스 (m)	분사 노즐	회전노즐	크기(mm) (L×W×H)
		최대허용	상용								
CPE2070A15XMA13L(수동) CPE2070A15XMA13A(자동)	CPE 150Z	150	130	13.2	7.5ps	선택(수동/자동)	34	10	○	선택사양	400X760X490
CPEZ140A27RKV15L CPEZ140A27RKV15S	CPE 275Z	275	250	15	14ps	○	70	10	○	선택사양	650X700X1,000

※ 상기 사양과 디자인은 사전 예고 없이 변경될 수 있습니다. ※ 500bar이상 (엔진형 사양 포함) 은 현장별로 맞춤 주문 제작 가능

무동력 파워 Sweepers - Kranzle 2+2

이중 롤러축 원리로 작동되는 무동력 파워 스위퍼



● 사양 및 특징

작업폭	저장탱크	제품중량	주문번호
800mm	40L	16kg	50076

- 내충격 플라스틱 재질의 저장탱크 및 하우징
- 최적 동력 전달을 위한 대형 천연 고무타이어 바퀴
- 내마모성 나일론 재질의 사이드 및 롤러 브러시
- 높낮이 조절 되는 사이드 브러시
- 브러시 무부하 장치 및 마이크로 필터의 사용으로 배출되는 공기세정



무동력 파워 Sweepers - Kranzle 1+1

쓰레받기 원리로 작동되는 무동력 파워 스위퍼



● 사양 및 특징

작업폭	저장탱크	제품중량	주문번호
670mm	40L	24kg	50077

- 내충격 플라스틱 재질의 저장탱크 및 하우징
- 최적 동력 전달을 위한 대형 천연 고무타이어 바퀴
- 내마모성 나일론 재질의 사이드 및 롤러 브러시
- 높낮이 조절 되는 사이드 브러시
- 브러시 무부하 장치 및 마이크로 필터의 사용으로 배출되는 공기세정



무동력 파워 Sweepers - Kranzle Colly 800

현대적인 디자인과 편리한 청소 기능



● 사양 및 특징

작업폭	저장탱크	제품중량	주문번호
800mm	30L	19kg	50079

- 유연한 실내 및 실외 청소 작업을 수행하도록 설계
- 내충격 플라스틱 재질의 저장탱크 및 하우징
- 최적 동력 전달을 위한 대형 천연 고무타이어 바퀴
- 내마모성 나일론 재질의 사이드 및 롤러 브러시
- 높낮이 조절 되는 사이드 브러시
- 브러시 무부하 장치 및 마이크로 필터의 사용으로 배출되는 공기세정



크란즐 진공청소기 Ventos-Series



● 특징

- 동급 대비 사용공간 (용기 체적에 대한 필터백의 체적)의 최대화
- 부가 장치 동시 사용을 위한 연결소켓, 기기 보호용 회로 내장
- 흡입 용량이 많아도 흡입 노즐 또는 그라인딩 도구 사용이 용이
- 액체를 흡입 시 최대 수위에 도달하면 터빈이 자동으로 정지
- 먼지가 끼지 않고 세탁이 가능한 내구성 높은 필터
- 저 중심 구조이며 어떤 지형에서도 (계단이나 발판) 쉽고 편리하게 이동
- 운반과 약세사리 사용이 쉽도록 케이스 뒤편에 약세사리 고정대 설치



주문번호	모 델	전 원	소비전력/소켓	흡입량 (ℓ/min)	진공도	소음도	전선 (m)	용량 (ℓ)	무게 (kg)
583910/583930	벤토스 20/30 E/L	230V, 60HZ	400-1200W/2400W	3700	240mbar	72dB(A)	7.5	17 / 32	9.4 / 9.9

● 구성품



필터 카트리지
주문번호 454403



흡입 호스 3.5m
주문번호 452819(36φ)



먼지백
주문번호 20E : 454400
30E : 454401



랜스 (스테인레스 스틸)
주문번호 584030



플로어 노즐
주문번호 584021



각진 핸드 파이프
주문번호 584029



플랫 노즐
주문번호 584023



가구 노즐
주문번호 584009



흡입 브러쉬
주문번호 584008





XTA 3G19



RKA 4G30



RGA 4G30



SXWA 5.5G50



SHP 22.50 / 15.50

특징

AR 펌프는 이탈리아 아노비 & 레베르베리사에서 설계제작된 고품질 고압펌프입니다.
 아노비 & 레베르베리 회사는 새로운 모델을 개발하기 위하여 엄격한 품질 테스트 과정을 거칩니다.
 제품설계 제작 후 24시간 연속 7일동안 사용한 후에 펌프의 압력 손실이 없는지, 부품 마모 여부,
 제품의 손상 여부를 정밀하게 검사한 후에 생산된 제품으로 소비자 여러분께 자신있게 권할 수 있는 제품입니다.



RTP 시리즈

사양

모델	압력 (Bar)	토출량 (ℓ/min)	회전수 (rpm)	소요동력 (Hp)	무게 (Kg)
모터형 펌프					
23010	XTA 3G19	130	11.4	1,750	4.0 5.0
23014	XMTA 3.5G22	150	13.2	1,750	5.5 6.5
23012	RKA 4G30	200	15.1	1,750	7.5 9.5
23697	RKA 4G40	275	15.1	1,750	11.0 9.5
23013	RKA 6.5G13	90	25.0	1,750	6.0 9.0
23691	RKA 7G20	140	27.0	1,750	10.0 9.5
27124	RWA 4G30H	200	15.1	1,750	7.5 14.5
21131	RKA 5.5G30	205	20.8	1,750	10.0 14.5
26053	RWA-S 5.5G30	205	20.8	1,750	10.0 16.0
21138	XWA 5.5G40	275	20.8	1,750	14.0 16.0
26054	XWA-S 8G29	200	30.2	1,750	15.0 16.0
21141	XWA 8G35	240	30.2	1,750	18.0 16.0
20183	XWA 9G16	110	34.0	1,750	10.0 16.0
20064	XWA 9G24	170	34.0	1,750	15.0 16.0
21006	SXWA 5.5G50	345	20.8	1,750	20.0 16.0
21211	SXWA 7G50	345	25.5	1,750	25.0 16.0
22175	XWL 36.15	150	36.0	1,450	15.0 16.0
26055	XWL-S 41.20	200	41.0	1,450	20.0 16.0
23709	XWL 50.15	150	50.0	1,450	20.0 16.0
21048	XWT 21.18	180	21.0	550	10.0 16.0
21826	SHP 22.50	500	22.0	1,450	27.0 16.0
23022	SHPA 4G70	500	15.1	1,750	20.0 16.0
22215	RTP 30.500	600	30.0	1,000	48.0 78.0
22982	RTP 30.600	275	70.0	1,000	51.0 90.0
22217	RTF 135.100	100	135.0	800	35.0 90.0
26105	RTD 130.160	160	130	1,000	54 58
21605	HYD-RK 15.20	200	15.0	1,450	7.5 9.7
21600	W/O HYD-RK 15.20	200	15.0	1,450	7.5 9.7
엔진용 펌프					
7455	XTV 3G20	140	11.4	3,400	5.5PS 5.0
21941	XMA 3.5G22J	150	13.2	1,800	6.5PS 6.5
21264	SXMV 4G35	240	15.1	3,400	13.0PS 6.5
20688	RKA 4G30J	200	15.1	1,800	11.0PS 9.5
21133	RKV 4G40	275	15.1	3,400	13.0PS 9.5
21135	RKV 5.5G40	275	20.8	3,400	18.0PS 10.5

모델	압력 (Bar)	토출량 (ℓ/min)	회전수 (rpm)	소요동력 (Hp)	무게 (Kg)
스테인레스 펌프(SUS316)					
20965	RKA-SS 3G15	103	11.4	1,750	3.0 10.0
20967	RKA-SS 4.2G15	103	15.9	1,750	4.3 10.0
21195	RKA-SS 7G22	150	27.0	1,750	11.0 10.0
24105	XWL-SS 50.15	150	50	1,450	20 18.0
21704	XWL-SS 42.15	150	42.0	1,450	15.0 18.0
23141	XWL-SS 33.08	80	33	950	7.5 18.0
26611	RTX-I 30.500	500	30.0	1,450	40 34.0
21468	XWL 42.05	50	42.0	1,450	5.5 18.0
27768	XM-SS 01.10	100	1.0	1,450	0.5 8.0
23425	XM-SS 02.10	100	2.0	1,450	0.5 8.0
24812	XM-SS 04.10	100	4.0	1,450	1.5 8.0
22124	XM-SS 11.17	170	11.0	1,450	5.5 7.0
온수용 펌프 85°C (Hot water)					
22543	XHW 11.17	170	11	1,450	5.0 6.5
22343	RHW 13.17	170	13	1,450	5.5 9.0
22987	WHW 21.15	150	21	1,450	7.5 16.0
22989	WHW 32.20	200	32	1,450	15.0 16.0
23967	WHWL 42.15	150	42	1,450	16.0 16.5
미스팅 펌프 (Misting)					
22092	XM-M 01.10	100	1	1,450	0.30 6.5
22093	XM-M 02.10	100	2	1,450	0.50 6.5
22094	XM-M 04.10	100	4	1,450	1.00 6.5
22095	XM-M 08.10	100	8	1,450	2.00 6.5
23432	RC-M 02.10	100	2	1,450	0.52 5.0
23083	RC-M 04.10	100	4	1,450	1.05 5.0
23444	RC-M 06.10	100	6	1,450	1.57 5.0
23441	RC-M 01.10	100	1	1,450	0.26 5.0
23442	RC-M 03.10	100	3	1,450	0.52 5.0
23443	RC-M 05.10	100	5	1,450	1.31 5.0

※기타 원하는 사양이 있으실 경우 수입진행 가능하오니 문의 부탁드립니다.



W951



W956



W921



HT 6315



WW 965



W4

● 특 징

인터펌프사의 펌프는 높은 수준의 기술, 정교한 자동화된 제조 과정, 우수한 품질 기준, 체계적인 연구와 혁신 그리고 디자인이 조화를 이뤄 기술적으로 널리 인정되는 제품입니다.

● 사 양

모 델	압 력 (Bar)	토출량 (ℓ/min)	회전수 (rpm)	소요동력 (Hp)	무 게 (kg)	모 델	압 력 (Bar)	토출량 (ℓ/min)	회전수 (rpm)	소요동력 (Hp)	무 게 (kg)
모터용 펌프						엔진용 펌프					
W 951	103	11.5	1,750	3.0	7.9	WW 961	172	15.0	3,400	6.5	8.7
W 953	172	11.5	1,750	5.0	7.9	WW 962	172	17.4	3,400	7.5	8.7
W 956	145	13.6	1,750	5.0	7.7	WW 965	250	15.0	3,400	10.0	8.7
W 995	90	13.0	1,750	3.0	8.5	스테인레스 펌프 (SUS316)					
W 921	200	15.0	1,750	7.5	14.5	SSU 1509	150	9.0	1,750	3.5	9.5
W 928	275	15.0	1,750	11.0	14.5	SSU 1511	150	11.0	1,750	4.5	9.5
WS 201	200	15.0	1,450	7.5	14.5	SSU 1413	138	13.0	1,750	4.7	9.5
WS 202	200	21.0	1,450	10.0	14.5	SSU 1415	138	15.2	1,750	5.5	9.5
T 5050	350	18.0	1,750	17.0	18.5	SSU 1515	150	15.0	1,750	5.5	15.0
WS 104	100	30.0	1,450	7.5	20.5	SSU 1518	150	18.0	1,750	7.0	15.0
WS 153	150	30.0	1,450	10.0	21.0	SSU 1521	150	21.0	1,750	7.5	15.0
W 4	50	42.0	600	5.5	16.5	SSU 1530	150	30.0	1,750	11.7	21.0
W 6	60	60.0	600	10.0	40.0	SSU 1535	150	35.0	1,750	13.6	21.0
W 8	60	75.0	600	12.5	40.0	SSU 1540	150	40.0	1,750	15.6	21.0
T 88	60	85.0	650	13.5	40.0	SSU 1550	150	50.0	1,750	19.5	21.0
W 155	150	53.0	1,000	20.0	41.0	온수용 펌프 (85℃)					
W 203	200	30.0	1,000	15.0	27.5	HT 6315	140	15	1,750	5.0	8.0
W 12	60	125.0	600	20.0	65.0	HT 6628	250	28	1,750	18.0	18.0
W 15	60	150.0	600	25.0	65.0	HT 6639	200	39	1,750	20.0	18.0
W 158	100	150.0	1,000	40.0	67.0	HT 6646	170	46	1,750	20.0	18.0
W 159	150	106.0	1,000	40.0	67.0	HT 6968	80	68	1,000	15.0	26.0
W 425	400	25.0	1,000	25.0	55.0	HT 7680	100	80	1,000	20.0	40.0



UDOR Pump



HAWK Pump

고압 펌프 시리즈

■ UDOR 펌프



PENTA-400



PENTA-500



GAMMA 95



GAMMA 200

모 델 (주문번호)	압 력 (Bar)	토출량 (ℓ/min)	회전수 (rpm)	소요동력 (Hp)	무 게 (kg)	모 델 (주문번호)	압 력 (Bar)	토출량 (ℓ/min)	회전수 (rpm)	소요동력 (Hp)	무 게 (kg)
PENTA-30/500 (883300)	500	30	1,450	40.0	47.0	GAMMA 95 TS	100	100	600	25.6	44.0
PENTA-35/400 (880600)	400	35	1,450	35.9	42.0	GAMMA 200 TS (792500)	80	200	600	41.0	69.0
PENTA-43/300 (880700)	300	43	1,450	33.1	42.0	GAMMA 105 TS (838700)	60	208	600	16.6	38.0
PENTA-70/200 (880000)	200	70	1,450	36.4	42.0	GAMMA 202 TS (837200)	60	208	600	32.0	52.0
CD 8.5/30S (901700)	200	32.2	1,740	16.5	18.8	CKD(GKD) 6.0/51S	250	18	1,740	11.5	17.4

■ HAWK 펌프



NMT 1220R



NMT 1820DX



NPM 1525R



NLT 3020IR

모 델 (주문번호)	압 력 (Bar)	토출량 (ℓ/min)	회전수 (rpm)	소요동력 (Hp)	무 게 (kg)	모 델 (주문번호)	압 력 (Bar)	토출량 (ℓ/min)	회전수 (rpm)	소요동력 (Hp)	무 게 (kg)
NMT 1220R (10990490)	200	15	1,740	7.7	9.5	NPM 1525R (10990610)	250	18	1,740	11.5	9.5
NMT 1820DX (10990540)	200	20	1,740	11	9.5	NLT 2525IR (10990740)	250	30	1,740	19.3	15.2
XLT 3325IR (10990980)	250	40	1,740	25.7	17.8	NLT 3020IR (10990760)	200	36	1,740	18.6	15.2
PX 2150IR (10991620)	500	26	1,740	33.1	19.2	XXT 4220IR (10991390)	200	51.1	1,740	26.3	18.4
HHP 30SR (50HZ) (10991960)	500	30	1,000	37	51	NPM 1725GR	250	11.5	3,400	7.2	10.5



RAVEL Motor

■ 고압펌프 전용 모터 (Hollow Shaft)



3 hp (단상)

주문번호 1095A



5.5 / 7.5 hp

주문번호 11109A / 11111A



10 hp

주문번호 1489A



15 / 20 hp

주문번호 1124A / 1397A



25 hp

주문번호 1798A

※ 라벨 모터는 내구성을 높이기 위해 산화처리 되어진(Anodizing) 제품입니다.

※ 모터보호등급: IP55



<p>RKA 4G30 주문번호 23012</p>  <table border="1"> <tr> <th>압력</th> <th>토출량</th> <th>동력</th> </tr> <tr> <td>200 Bar</td> <td>15 L/min</td> <td>7.5 hp (5.5kw)</td> </tr> </table>	압력	토출량	동력	200 Bar	15 L/min	7.5 hp (5.5kw)	<p>체크밸브</p>  <p>KIT 2864</p>	<p>패킹</p>  <p>구형은 저압이 고무입니다.</p> <p>KIT 1857 (구형) KIT 42473 (신형)</p>	<p>리데나(오일씰) 주문번호 880520</p>  <p>3 pcs (1대분)</p>	<p>세라믹 피스톤 18ϕ 주문번호 1380940</p>  <p>갈색 or 흰색 3 pcs (1대분)</p>
압력	토출량	동력								
200 Bar	15 L/min	7.5 hp (5.5kw)								
<p>XMTA 3.5G22 주문번호 23014</p>  <table border="1"> <tr> <th>압력</th> <th>토출량</th> <th>동력</th> </tr> <tr> <td>150 Bar</td> <td>13.2 L/min</td> <td>5.5 hp (3.7kw)</td> </tr> </table>	압력	토출량	동력	150 Bar	13.2 L/min	5.5 hp (3.7kw)	<p>체크밸브</p>  <p>KIT 1864</p>	<p>패킹</p>  <p>구형은 저압이 고무입니다.</p> <p>KIT 2741(구형) KIT 42652 (신형)</p>	<p>리데나(오일씰) 주문번호 1260460</p>  <p>3 pcs (1대분)</p>	<p>세라믹 피스톤 15ϕ 주문번호 1780070</p>  <p>갈색 or 흰색 3 pcs (1대분)</p>
압력	토출량	동력								
150 Bar	13.2 L/min	5.5 hp (3.7kw)								
<p>RKV 4G40 주문번호 21133</p>  <table border="1"> <tr> <th>압력</th> <th>토출량</th> <th>동력</th> </tr> <tr> <td>275 Bar</td> <td>15.1 L/min</td> <td>13 ps</td> </tr> </table>	압력	토출량	동력	275 Bar	15.1 L/min	13 ps	<p>체크밸브</p>  <p>KIT 1828</p>	<p>패킹</p>  <p>KIT 1857</p>	<p>리데나(오일씰) 주문번호 880520</p>  <p>3 pcs (1대분)</p>	<p>세라믹 피스톤 18ϕ 주문번호 1380940</p>  <p>갈색 or 흰색 3 pcs (1대분)</p>
압력	토출량	동력								
275 Bar	15.1 L/min	13 ps								
<p>XTA 3G19 주문번호 23010</p>  <table border="1"> <tr> <th>압력</th> <th>토출량</th> <th>동력</th> </tr> <tr> <td>130 Bar</td> <td>11.4 L/min</td> <td>4 hp (3kw)</td> </tr> </table>	압력	토출량	동력	130 Bar	11.4 L/min	4 hp (3kw)	<p>체크밸브</p>  <p>KIT 1864</p>	<p>패킹</p>  <p>KIT 1874</p>	<p>리데나(오일씰) 주문번호 1260460</p>  <p>3 pcs (1대분)</p>	<p>세라믹 피스톤 18ϕ 주문번호 1260210</p>  <p>갈색 or 흰색 3 pcs (1대분)</p>
압력	토출량	동력								
130 Bar	11.4 L/min	4 hp (3kw)								
<p>SXWA 5.5G50 주문번호 21006</p>  <table border="1"> <tr> <th>압력</th> <th>토출량</th> <th>동력</th> </tr> <tr> <td>345 Bar</td> <td>20.8 L/min</td> <td>20 hp (13.4kw)</td> </tr> </table>	압력	토출량	동력	345 Bar	20.8 L/min	20 hp (13.4kw)	<p>체크밸브</p>  <p>KIT 2871</p>	<p>패킹</p>  <p>KIT 2874</p>	<p>리데나(오일씰) 주문번호 1940560</p>  <p>3 pcs (1대분)</p>	<p>세라믹 피스톤 18ϕ 주문번호 1941020</p>  <p>갈색 or 흰색 3 pcs (1대분)</p>
압력	토출량	동력								
345 Bar	20.8 L/min	20 hp (13.4kw)								



<p>RKA 7G20 주문번호 23691</p>  <table border="1"> <tr> <th>압력</th> <th>토출량</th> <th>동력</th> </tr> <tr> <td>140 Bar</td> <td>27 L/min</td> <td>10 hp (7.5 kw)</td> </tr> </table>	압력	토출량	동력	140 Bar	27 L/min	10 hp (7.5 kw)	<p>체크밸브</p>  <p>KIT 2864</p>	<p>패킹</p>  <p>KIT 42551</p>	<p>리데나(오일씰) 주문번호 880520</p>  <p>3 pcs (1대분)</p>	<p>세라믹 피스톤 22ϕ 주문번호 1382360</p>  <p>갈색 or 흰색 3 pcs (1대분)</p>
압력	토출량	동력								
140 Bar	27 L/min	10 hp (7.5 kw)								
<p>RKA-SS 7G22 주문번호 21195</p>  <table border="1"> <tr> <th>압력</th> <th>토출량</th> <th>동력</th> </tr> <tr> <td>150 Bar</td> <td>27 L/min</td> <td>11 hp (8.2 kw)</td> </tr> </table>	압력	토출량	동력	150 Bar	27 L/min	11 hp (8.2 kw)	<p>체크밸브</p>  <p>KIT 2514</p>	<p>패킹</p>  <p>KIT 2527</p>	<p>리데나(오일씰) 주문번호 880520</p>  <p>3 pcs (1대분)</p>	<p>세라믹 피스톤 22ϕ 주문번호 1383340</p>  <p>갈색 or 흰색 3 pcs (1대분)</p>
압력	토출량	동력								
150 Bar	27 L/min	11 hp (8.2 kw)								
<p>RWA-S 5.5G30 주문번호 26053</p>  <table border="1"> <tr> <th>압력</th> <th>토출량</th> <th>동력</th> </tr> <tr> <td>205 Bar</td> <td>20 L/min</td> <td>11 hp (8.2kw)</td> </tr> </table>	압력	토출량	동력	205 Bar	20 L/min	11 hp (8.2kw)	<p>체크밸브</p>  <p>KIT 42169</p>	<p>패킹</p>  <p>KIT 42171</p>	<p>리데나(오일씰) 주문번호 1940560</p>  <p>3 pcs (1대분)</p>	<p>세라믹 피스톤 18ϕ 주문번호 1941020</p>  <p>갈색 or 흰색 3 pcs (1대분)</p>
압력	토출량	동력								
205 Bar	20 L/min	11 hp (8.2kw)								
<p>RRA 4G36 주문번호 24937</p>  <table border="1"> <tr> <th>압력</th> <th>토출량</th> <th>동력</th> </tr> <tr> <td>250 Bar</td> <td>15 L/min</td> <td>8.6 hp (6.4kw)</td> </tr> </table>	압력	토출량	동력	250 Bar	15 L/min	8.6 hp (6.4kw)	<p>체크밸브</p>  <p>KIT 2864</p>	<p>패킹</p>  <p>KIT 42549</p>	<p>리데나(오일씰) 주문번호 1260460</p>  <p>3 pcs (1대분)</p>	<p>세라믹 피스톤 18ϕ 주문번호 1780080</p>  <p>갈색 or 흰색 3 pcs (1대분)</p>
압력	토출량	동력								
250 Bar	15 L/min	8.6 hp (6.4kw)								
<p>RKA 4G40 주문번호 23697</p>  <table border="1"> <tr> <th>압력</th> <th>토출량</th> <th>동력</th> </tr> <tr> <td>275 Bar</td> <td>15.1 L/min</td> <td>11 hp (8.2kw)</td> </tr> </table>	압력	토출량	동력	275 Bar	15.1 L/min	11 hp (8.2kw)	<p>체크밸브</p>  <p>KIT 2864</p>	<p>패킹</p>  <p>KIT 1857 KIT 42473</p>	<p>리데나(오일씰) 주문번호 880520</p>  <p>3 pcs (1대분)</p>	<p>세라믹 피스톤 18ϕ 주문번호 1380490</p>  <p>갈색 or 흰색 3 pcs (1대분)</p>
압력	토출량	동력								
275 Bar	15.1 L/min	11 hp (8.2kw)								

※부품의 디자인 및 구성이 변경 될 수도 있습니다.



RRV 4G40 주문번호 24935



압력 275 Bar | 토출량 15.1 L/min | 동력 13 kw

체크밸브



KIT 1828

패킹



KIT 42556

리데나(오일씰) 주문번호 1260460



3 pcs (1대분)

세라믹 피스톤 18φ 주문번호 1780070



갈색 or 흰색 3 pcs (1대분)

RTX 60.300 주문번호 26068



압력 300 Bar | 토출량 60 L/min | 동력 47 hp (35kw)

체크밸브



KIT 42835

패킹



KIT 42842

리데나(오일씰) 주문번호 3660310



3 pcs (1대분)

세라믹 피스톤 25φ 주문번호 3660150



갈색 or 흰색 3 pcs (1대분)

RTP 30.600 주문번호 22982



압력 600 Bar | 토출량 30 L/min | 동력 48 hp (36kw)

체크밸브



KIT 42156

패킹



KIT 42159

리데나(오일씰) 주문번호 282360



3 pcs (1대분)

세라믹 피스톤 20φ 주문번호 2821910



갈색 or 흰색 3 pcs (1대분)

SXWA 7G50 주문번호 21211



압력 345 Bar | 토출량 25.5 L/min | 동력 22 hp (16.2kw)

체크밸브



KIT 2780

패킹



KIT 2874

리데나(오일씰) 주문번호 1940560



3 pcs (1대분)

세라믹 피스톤 18φ 주문번호 1941020



갈색 or 흰색 3 pcs (1대분)

SHP 15.50 / 22.50 주문번호 21825



압력 500 Bar | 토출량 15 L/min | 동력 20 hp(15kw)
500 Bar | 토출량 22 L/min | 동력 27 hp(20kw)

체크밸브



KIT 2185

패킹



KIT 2874

리데나(오일씰) 주문번호 1940560



3 pcs (1대분)

세라믹 피스톤 18φ 주문번호 1941020



갈색 or 흰색 3 pcs (1대분)

※부품의 디자인 및 구성이 변경 될 수도 있습니다.



XM-M 02.10 주문번호 22093



압력	토출량	동력
100 Bar	2 L/min	0.5 hp (0.4kw)

체크밸브



KIT 1864

패킹



KIT 2741 (구형)
KIT 42652 (신형)

리데나(오일씰)
주문번호 1260460



3 pcs (1대분)

세라믹 피스톤
15φ
주문번호 1780070



갈색 or 흰색
3 pcs (1대분)

XWLA 13G15 주문번호 21198



압력	토출량	동력
100 Bar	49.2 L/min	13 hp (9.6kw)

체크밸브



KIT 2780

패킹



KIT 42708

리데나(오일씰)
주문번호 1940560



3 pcs (1대분)

세라믹 피스톤
28φ
주문번호 1140190



갈색 or 흰색
3 pcs (1대분)

XWP 70.12 / 60.13
주문번호 26287 주문번호 26285



압력	토출량	동력
120 Bar	70 L/min	20 hp(15kw)
130 Bar	60 L/min	20 hp(15kw)

체크밸브



KIT 42835

패킹



KIT 43446

리데나(오일씰)
주문번호 1943730



3 pcs (1대분)

세라믹 피스톤
30φ
주문번호 1943610



갈색 or 흰색
3 pcs (1대분)

XMA-J 3.5G22 주문번호 21941



압력	토출량	동력
150 Bar	13.2 L/min	6.5 ps

체크밸브



KIT 1864

패킹



KIT 2741 (구형)
KIT 42652 (신형)

리데나(오일씰)
주문번호 1260460



3 pcs (1대분)

세라믹 피스톤
15φ
주문번호 1780070



갈색 or 흰색
3 pcs (1대분)

XWL 36.15 / 50.15
주문번호 22175 주문번호 23709



압력	토출량	동력
150 Bar	36 L/min	15 hp(11kw)
150 Bar	50 L/min	20 hp(15kw)

체크밸브



KIT 2780

패킹



KIT 1853

리데나(오일씰)
주문번호 1940560



3 pcs (1대분)

세라믹 피스톤
28φ
주문번호 1140190



갈색 or 흰색
3 pcs (1대분)

※부품의 디자인 및 구성이 변경 될 수도 있습니다.



XWF 36.17 주문번호 21056



압력	토출량	동력
170 Bar	36 L/min	15 hp (11kw)

체크밸브



KIT 2780

패킹



KIT 42708
Viton Ver. 패킹
KIT 46244

리데나(오일씰)
주문번호 1940560



3 pcs (1대분)

세라믹 피스톤
28φ
주문번호 1140190



갈색 or 흰색
3 pcs (1대분)

XWT 21.18 주문번호 21048



압력	토출량	동력
180 Bar	21 L/min	10 hp (7.5kw)

체크밸브



KIT 2780

패킹



KIT 42708

리데나(오일씰)
주문번호 1940560



3 pcs (1대분)

세라믹 피스톤
28φ
주문번호 1140190



갈색 or 흰색
3 pcs (1대분)

XWA-S 8G29 주문번호 26054



압력	토출량	동력
200 Bar	30 L/min	15 hp (11kw)

체크밸브



KIT 2780

패킹



일반 : KIT 2782
테프론 : KIT 43436

리데나(오일씰)
주문번호 1940560



3 pcs (1대분)

세라믹 피스톤
20φ
주문번호 1942330
8G29-Brass
주문번호 1420430



갈색 or 흰색
3 pcs (1대분)

XWL-S 41.20 주문번호 26055



압력	토출량	동력
200 Bar	41 L/min	20 hp (15kw)

체크밸브



KIT 2162

패킹



일반 : KIT 2164
테프론 : KIT 43052

리데나(오일씰)
주문번호 1940560



3 pcs (1대분)

세라믹 피스톤
28φ
주문번호 2520240



갈색 or 흰색
3 pcs (1대분)

HYD-RK 15.20
(유압모터타입) (펌프/유압모터 W/O)
주문번호 21605 주문번호 21600



SNM2NN/019
BN06GAM1F5F5N

φ	19.2
bar	140
l/min	29
rpm	1450
kg	9.7

압력	토출량	동력
200 Bar	15 L/min	7.5 hp

체크밸브



KIT 2864

패킹



KIT 1857 (구형)
KIT 42473 (신형)

리데나(오일씰)
주문번호 880520



3 pcs (1대분)

세라믹 피스톤
18φ
주문번호 380490



갈색 or 흰색
3 pcs (1대분)

※부품의 디자인 및 구성이 변경 될 수도 있습니다.



W951



압력	토출량	동력
103 Bar	11.5 L/min	3 hp (2.2kw)

체크밸브



KIT 123

패킹



KIT 88

리데나(오일씰)
주문번호 KIT 23



3 pcs (1대분)

세라믹 피스톤
15 ϕ
주문번호 52040009



갈색 or 흰색
3 pcs (1대분)

W956



압력	토출량	동력
145 Bar	13.6 L/min	5 hp (3.67kw)

체크밸브



KIT 123

패킹



KIT 127

리데나(오일씰)
주문번호 KIT 23



3 pcs (1대분)

세라믹 피스톤
18 ϕ
주문번호 44040109



갈색 or 흰색
3 pcs (1대분)

W921



압력	토출량	동력
200 Bar	15 L/min	7.5 hp (5.6kw)

체크밸브



KIT 1

패킹



KIT 69

리데나(오일씰)
주문번호 KIT 2



3 pcs (1대분)

세라믹 피스톤
20 ϕ
주문번호 47040409



갈색 or 흰색
3 pcs (1대분)

W928



압력	토출량	동력
275 Bar	15 L/min	11 hp (8.08 kw)

체크밸브



KIT 1

패킹



KIT 109

리데나(오일씰)
주문번호 KIT 2



3 pcs (1대분)

세라믹 피스톤
16 ϕ
주문번호 47040856



갈색 or 흰색
3 pcs (1대분)

HT 6315 (HOT)



압력	토출량	동력
150 Bar	36 L/min	15 hp (11kw)

체크밸브



KIT 123

패킹



KIT 204 (Viton)

리데나(오일씰)
주문번호 KIT 59



3 pcs (1대분)

세라믹 피스톤
18 ϕ
주문번호 44040109



갈색 or 흰색
3 pcs (1대분)

※부품의 디자인 및 구성이 변경 될 수도 있습니다.

■ HAWK Pumps

<p>NHD 1215</p>  <table border="1"> <tr> <th>압력</th> <th>토출량</th> <th>동력</th> </tr> <tr> <td>150 Bar</td> <td>14 L/min</td> <td>5.4 hp (4kw)</td> </tr> </table>	압력	토출량	동력	150 Bar	14 L/min	5.4 hp (4kw)	<p>체크밸브</p>  <p>260012</p>	<p>패킹</p>  <p>260189</p>	<p>리데나(오일씰) 주문번호 000105</p>  <p>3 pcs (1대분)</p>	<p>세라믹 피스톤 16φ 주문번호 120045</p>  <p>갈색 or 흰색 3 pcs (1대분)</p>			
압력	토출량	동력											
150 Bar	14 L/min	5.4 hp (4kw)											
<p>NMT 1220 / 1820</p>  <table border="1"> <tr> <th>압력</th> <th>토출량</th> <th>동력</th> </tr> <tr> <td>200 Bar</td> <td>15 L/min</td> <td>7.7 hp (5.7kw)</td> </tr> <tr> <td>200 Bar</td> <td>21.4 L/min</td> <td>11 hp (8.1kw)</td> </tr> </table>	압력	토출량	동력	200 Bar	15 L/min	7.7 hp (5.7kw)	200 Bar	21.4 L/min	11 hp (8.1kw)	<p>체크밸브</p>  <p>260008</p>	<p>패킹</p>  <p>260077</p>	<p>리데나(오일씰) 주문번호 000103</p>  <p>3 pcs (1대분)</p>	<p>세라믹 피스톤 20φ 주문번호 120010</p>  <p>갈색 or 흰색 3 pcs (1대분)</p>
압력	토출량	동력											
200 Bar	15 L/min	7.7 hp (5.7kw)											
200 Bar	21.4 L/min	11 hp (8.1kw)											
<p>NMT 1220 (HOT ver.)</p>  <table border="1"> <tr> <th>압력</th> <th>토출량</th> <th>동력</th> </tr> <tr> <td>200 Bar</td> <td>15 L/min</td> <td>7.7 hp (5.7kw)</td> </tr> </table>	압력	토출량	동력	200 Bar	15 L/min	7.7 hp (5.7kw)	<p>체크밸브</p>  <p>260008</p>	<p>패킹</p>  <p>260121 (Viton)</p>	<p>리데나(오일씰) 주문번호 000103</p>  <p>3 pcs (1대분)</p>	<p>세라믹 피스톤 20φ 주문번호 120010</p>  <p>갈색 or 흰색 3 pcs (1대분)</p>			
압력	토출량	동력											
200 Bar	15 L/min	7.7 hp (5.7kw)											
<p>XXT 4220 (세라믹 KIT)</p>  <table border="1"> <tr> <th>압력</th> <th>토출량</th> <th>동력</th> </tr> <tr> <td>200 Bar</td> <td>51.1 L/min</td> <td>26.3 hp (19.3kw)</td> </tr> </table>	압력	토출량	동력	200 Bar	51.1 L/min	26.3 hp (19.3kw)	<p>체크밸브</p>  <p>260144</p>	<p>패킹</p>  <p>10997690</p>	<p>리데나(오일씰) 주문번호 10997660</p>  <p>3 pcs (1대분)</p>	<p>세라믹 피스톤 22φ 주문번호 10997760</p>  <p>갈색 or 흰색 3 pcs (1대분)</p>			
압력	토출량	동력											
200 Bar	51.1 L/min	26.3 hp (19.3kw)											
<p>XLT 2730</p>  <table border="1"> <tr> <th>압력</th> <th>토출량</th> <th>동력</th> </tr> <tr> <td>300 Bar</td> <td>32 L/min</td> <td>24.6 hp (18.1kw)</td> </tr> </table>	압력	토출량	동력	300 Bar	32 L/min	24.6 hp (18.1kw)	<p>체크밸브</p>  <p>260131</p>	<p>패킹</p>  <p>260126</p>	<p>리데나(오일씰) 주문번호 000101</p>  <p>3 pcs (1대분)</p>	<p>세라믹 피스톤 20φ 주문번호 120032</p>  <p>갈색 or 흰색 3 pcs (1대분)</p>			
압력	토출량	동력											
300 Bar	32 L/min	24.6 hp (18.1kw)											

1EA(1KIT)
(* 31~34번)

※부품의 디자인 및 구성이 변경 될 수도 있습니다.

<p>NPM 1725 GR</p>  <p>압력 토출량 동력 250 Bar 17 L/min 13 PS</p>	<p>체크밸브</p>  <p>19055430</p>	<p>패킹</p>  <p>10998350</p>	<p>리데나(오일씰) 주문번호 10997510</p>  <p>3 pcs (1대분)</p>	<p>세라믹 피스톤 15ϕ 15ϕx9x46 주문번호 120025</p>  <p>갈색 or 흰색 3 pcs (1대분)</p>
<p>NPM 1525</p>  <p>압력 토출량 동력 250 Bar 18 L/min 11.5 hp (8.5kw)</p>	<p>체크밸브</p>  <p>260008</p>	<p>패킹</p>  <p>260079</p>	<p>리데나(오일씰) 주문번호 000103</p>  <p>3 pcs (1대분)</p>	<p>세라믹 피스톤 18ϕ 주문번호 120009</p>  <p>갈색 or 흰색 3 pcs (1대분)</p>
<p>XLT 3325</p>  <p>압력 토출량 동력 250 Bar 40 L/min 25.7 hp (18.8 kw)</p>	<p>체크밸브</p>  <p>260131</p>	<p>패킹</p>  <p>260125</p>	<p>리데나(오일씰) 주문번호 000101</p>  <p>3 pcs (1대분)</p>	<p>세라믹 피스톤 22ϕ 주문번호 120034</p>  <p>갈색 or 흰색 3 pcs (1대분)</p>
<p>UDOR Pumps</p>				
<p>CD 8.5/30S 주문번호 901700</p>  <p>압력 토출량 동력 200 Bar 32.2 L/min 16.5 hp (12.1 kw)</p>	<p>체크밸브</p>  <p>CD 606103(KIT 30)</p>	<p>패킹</p>  <p>CD 606110(KIT 10)</p>	<p>리데나(오일씰) 주문번호 000781</p>  <p>3 pcs (1대분)</p>	<p>세라믹 피스톤 22ϕ 주문번호 120532</p>  <p>갈색 or 흰색 3 pcs (1대분)</p>
<p>CKD(GKD)6.0/51S 주문번호 294400</p>  <p>압력 토출량 동력 350 Bar 22.7 L/min 20.4 hp (155kw)</p>	<p>체크밸브</p>  <p>GKD 606141 (KIT 41) CKD 606163 (KIT 63)</p>	<p>패킹</p>  <p>GKD 606109 (KIT 09) CKD 6061D4 (KIT 129)</p>	<p>리데나(오일씰) 주문번호 000781</p>  <p>3 pcs (1대분)</p>	<p>세라믹 피스톤 20ϕ 주문번호 120531</p>  <p>갈색 or 흰색 3 pcs (1대분)</p>

※부품의 디자인 및 구성이 변경 될 수도 있습니다.

● by-pass valve (압력조절밸브, 언로더 밸브)



주문번호 0215010260
VRT 3
 압력: 310 bar
 토출량: 40 L/min
 IN: 3/8 F
 OUT: 3/8 F
 Bypass: 3/8 F
 테코맥(Italy)



주문번호 60000760
Puls RV
 압력: 310 bar
 토출량: 40 L/min
 IN: 3/8 F
 OUT: 3/8 F
 Bypass: 3/8 F
 피에이(Italy)



주문번호 4072000096
VRT 3 (해수용)
 압력: 310 bar
 토출량: 40 L/min
 IN: 3/8 F
 OUT: 3/8 F
 Bypass: 3/8 F
 테코맥(Italy)



주문번호 60235000
VB 9 + PR
 압력: 250 bar
 토출량: 30 L/min
 IN: 3/8 F
 OUT: 3/8 F
 Bypass: 3/8 F
 피에이(Italy)



주문번호 4072000007
VRT 3 + PR
 압력: 310 bar
 토출량: 40 L/min
 IN: 3/8 F
 OUT: 3/8 F
 Bypass: 3/8 F
 테코맥(Italy)



주문번호 60000660
Puls RV + PR
 압력: 310 bar
 토출량: 40 L/min
 IN: 3/8 F
 OUT: 3/8 F
 Bypass: 3/8 F
 피에이(Italy)



주문번호 60070000
VB 7
 압력: 250 bar
 토출량: 30 L/min
 IN: 3/8 M
 OUT: 3/8 F
 Bypass: 3/8 F
 피에이(Italy)



주문번호 RK용 60000760
XM용 60076500
INTER 용 60093000
VB 75
 압력: 250 bar
 토출량: 30 L/min
 IN: 3/8 M
 OUT: 1/2 M
 피에이(Italy)
*4G30, 3.5G22/W951, W956전용



주문번호 60225000
VB 9
 압력: 250 bar
 토출량: 30 L/min
 IN: 3/8 F
 OUT: 3/8 F
 Bypass: 3/8 F
 피에이(Italy)



주문번호 60185050
VB 33
 압력: 310 bar
 토출량: 80 L/min
 IN: 1/2 F
 OUT: 1/2 F
 Bypass: 1/2 F
 피에이(Italy)



주문번호 60042760
VB 85R / 280
 압력: 310 bar
 토출량: 80 L/min
 IN: 1/2 F
 OUT: 1/2 F
 Bypass: 1/2 F
 피에이(Italy)



주문번호 4072000033
VRT 100
 압력: 310 bar
 토출량: 100 L/min
 IN: G1/2F
 OUT: G1/2F
 Bypass: 1/2 F
 피에이(Italy)



주문번호 TIMAX
주문번호 TIMAX 100
 압력: 60 bar
 토출량: 200 L/min
 IN: 3/4F
 OUT: 1/2F
 Bypass: 1F
 인터펌프(Italy)



주문번호 60502015
VB200 / 150
 압력: 150 bar
 토출량: 200 L/min
 IN: 1F
 OUT: 1F
 Bypass: 1F
 피에이(Italy)



주문번호 20821
Minimatic
 압력: 180 bar
 토출량: 18 L/min
 IN: 1/2 F
 OUT: 3/8 M
 아노비(Italy)

※ 다른 사양의 제품을 원하실 경우 문의 바랍니다.

● by-pass valve (압력조절밸브, 언로더 밸브)



주문번호 60170000
VB 350
 압력: 390 bar
 토출량: 40 L/min
 IN: 3/8 M
 OUT: 3/8 F
 Bypass: 1/2 F
 피에이(Italy)



주문번호 407200011
VHP 39
 압력: 390 bar
 토출량: 40 L/min
 IN: 3/8 F
 OUT: 3/8 F
 Bypass: 3/8 F
 테코맥 (Italy)



주문번호 60045580
VB 80 / 400
 압력: 450 bar
 토출량: 80 L/min
 IN: 1/2 F
 OUT: 1/2 F
 Bypass: 1/2 F
 피에이 (Italy)



주문번호 H560
H 560
 압력: 500 bar
 토출량: 60 L/min
 IN: 1/2 F
 OUT: 3/8 M
 Bypass 1/2 F
 인터펌프 (Italy)



주문번호 60147000
VB 53
 압력: 550 bar
 토출량: 80 L/min
 IN: 3/8 M
 OUT: 3/8 F
 Bypass: 3/8 F
 피에이(Italy)



주문번호 4072201000
VHP 70
 압력: 700 bar
 토출량: 80 L/min
 IN: 1/2 F
 OUT: 1/2 F
 Bypass: 1/2 F
 테코맥 (Italy)

● Safety Valve (안전밸브)



주문번호 60510000
VS 200 / 180
 압력: 200 bar
 토출량: 200 L/min
 IN: 3/8 F
 Bypass: 1/2 F
 피에이(Italy)



주문번호 60052500
VS 220
 압력: 250 bar
 토출량: 24 L/min
 IN: 3/8 F
 Bypass: 3/8 F
 피에이(Italy)



주문번호 60059060
VS 80 / 280
 압력: 300 bar
 토출량: 80 L/min
 재질 : SUS316
 IN/OUT :1/2
 Couplings: 1/2 F
 피에이(Italy)



주문번호 60152000
VS 360
 압력: 390 bar
 토출량: 40 L/min
 IN: 3/8 MF
 Bypass: 1/2 F
 피에이(Italy)



주문번호 0215010420
SVT 40
 압력: 400 bar
 토출량: 25 L/min
 IN: 3/8 FF
 OUT: 3/8 FF
 Bypass: 3/8 F
 테코맥 (Italy)



주문번호 60055000
VS 80 / 400
 압력: 450 bar
 토출량: 80 L/min
 IN: 1/2 F
 OUT: 3/8 FF
 Bypass: 1/2 F
 피에이(Italy)



주문번호 50520000
VS 500
 압력: 560 bar
 토출량: 80 L/min
 IN: 1/2 F
 Bypass: 3/8 F
 피에이(Italy)



주문번호 60065000
VS 660
 압력: 720 bar
 토출량: 60 L/min
 IN: 3/8 F
 Bypass: 1/2 F
 피에이(Italy)



주문번호 S 3
S 3
 압력: 840 bar
 토출량: 100 L/min
 IN: 1/2 M
 인터펌프(Italy)

※ 다른 사양의 제품을 원하실 경우 문의 바랍니다.

주문번호 60170000

● Filter (필터)

주문번호 009020508
필터 AL+Blue
 1/2 MF
 (45 mesh)



주문번호 009020508-CLP
필터 B-AL
 1/2 MF
 (45 mesh)



주문번호 ZAFIL
필터 INTER
 1/2 MF
 (45 mesh)



신주 Y 필터
 1/2 FF : 주문번호 0211000520
 3/4 FF : 주문번호 0211000530
 (45 mesh)



PL 필터
 1/2 FF : 주문번호 8105039
 3/4 FF : 주문번호 8105043
 (100 mesh)



주문번호 0211001090
MV 18
 1/2 MF
 (50 mesh)



F5
 1/2 FF : 주문번호 28035020
 1/2 FM : 주문번호 28030000
 (50 mesh)



FY5
 1 FF : 주문번호 15000402
 3/4 FF : 주문번호 15000412
 (50 mesh)



주문번호 8105011
G1F
 1 FF
 (100 mesh)



주문번호 0211001110
MV 19 (Line)
 3/4 FM
 (200 mesh)



F30 (2Ø) : 주문번호 25583
F40 (3Ø) : 주문번호 25577
 (80 mesh)



마이크로필터하우징
 1/2 FF : 주문번호 12HOUSING
 3/4 FF : 주문번호 13HOUSING



10미크론 (25cm)
 주문번호 463055Z10
50미크론 (25cm)
 주문번호 463055Z50

필터 단상 (크란즐)
 주문번호 410462



필터 삼상 (크란즐)
 주문번호 410461



K1050P 필터 (크란즐)
 주문번호 13311



주문번호 133003
Therm 필터 (크란즐)
 3/4 MF



자흡필터 + 호스 3m + 커플링
 주문번호 43011Z



자흡필터 + 호스 3m (크란즐)
 주문번호 150383



※ 다른 사양의 제품을 원하실 경우 문의 바랍니다.

● GUN (건)

RL 26 S/W
280/30



IN: 3/8F
OUT: 1/4F

주문번호 30175800

RL 30 S/W
350/40



IN: 3/8F
OUT: 1/4F

주문번호 30251100

RL 26 S/W WEEP
280/30



IN: 3/8F
OUT: 1/4F

주문번호 30179400

RL 51 S/W
280/50



IN: 3/8F
OUT: 1/4F

주문번호 30412010

RL 56 S/W
390/30



IN: 3/8F
OUT: 1/4F

주문번호 30452010

RL 57 S/W
500/28



IN: 3/8F
OUT: 1/4F

주문번호 30470000

RL 84
560/80



IN: 3/8F
OUT: 1/4F

주문번호 30540000

LINEAR 3 S/W
350/40



IN: 3/8F
OUT: 1/4F

주문번호 30064000

NOVA 400
440/40



IN: 3/8F
OUT: 1/4F

주문번호 30565000

RL 600
660/60



IN: 3/8F
OUT: 3/8F

주문번호 30580000

RL 204(220/200)
주문번호 30520000



IN: 3/4F
OUT: 1/2F

RL 204 S/W 주문번호 30523000

RL 124
135/120



IN: 1/2F
OUT: 1/2F

주문번호 30530000

ML 960 SUS S/W
550/30



IN: 3/8F
OUT: 1/4F

주문번호 4017000049

MV 925 S/W WEEP
310/30



IN: 3/8F
OUT: 1/4F

주문번호 4012405010

MV 925 S/W
(단상)



IN: M22
OUT: M22

주문번호 4022205006

M2000
(단상)



IN: M22
OUT: M22

주문번호 12480

Starlet II
(삼상)



IN: M22
OUT: M22

주문번호 123202

M2000 - short



주문번호 12425 (055노즐)
주문번호 12492

IN: M22
OUT: M22

* AR3 호환가능

AL 55
250/45



주문번호 30175800

IN: 3/8F
OUT: M15



※ 다른 사양의 제품을 원하실 경우 문의 바랍니다.

● Nozzle (노즐)

<p>직사노즐 기준 045 주문번호 00045</p> 	<p>분사노즐 기준 045 주문번호 15045 25045 40045 65045</p> 	<p>파이프크리닝 1/8 (크란즐)</p>  <p>주문번호 KNF055(정역) 1/8 KNF045(정역) 1/8 KN055(역) 1/8 KN045(역) 1/8</p>	<p>파이프크리닝 1/4 (크란즐)</p>  <p>주문번호 KKF04~10(정역) 1/4 KK04~10(역) 1/4</p>	<p>파이프크리닝 3/8 (크란즐)</p>  <p>주문번호 KKF12 (정역) 3/8</p>
<p>파이프크리닝 1/8 (MV)</p>  <p>주문번호 0124722000 1/8 04(역) 0124722010 1/8 450(역) 0124722020 1/8 055(역) 0124722210 1/8 450(정역)</p>	<p>파이프크리닝 1/4 (MV)</p>  <p>주문번호 0124722050 1/4 045(역) 0124722060 1/4 055(역) 0124722250 1/4 045(정역) 0124722090 3/8 045(역) 0124722100 3/8 055(역)</p>	<p>파이프크리닝 회전 (MV)</p>  <p>주문번호 0124722520 045 1/8 0124722570 045 1/4</p>	<p>파이프크리닝 스틱터(회전) (슈트너)</p>  <p>주문번호 200049950 1/8 05 (역) 200049970 1/8 07 (역) 200049892 3/8 10 (역) 200049893 3/8 12 (역) 200049795 1/4 045 (역) 200049805 1/4 055 (역) 200049820 1/4 08 (역) 200049896 3/8 10 (정역)</p>	<p>파이프크리닝 회전 (크란즐)</p>  <p>주문번호 KNR 045 1/4 KNR 055 1/4</p>
<p>파이프크리닝 RU 30/50/80 (PA) 300bar</p>  <p>주문번호 25123630 (RU30) 25123750 (RU50) 25123980 (RU80)</p>	<p>파이프크리닝 RR-TF 노즐(PA) 300bar</p>  <p>주문번호 25485040</p>	<p>바리오노즐 (크란즐) 250bar</p>  <p>주문번호 03 : 411558 045 : 41155</p>	<p>회전노즐 (크란즐) 220bar</p>  <p>주문번호 045 : 410713 035 : 410734 055 : 410714</p>	<p>터보노즐 (크란즐) 320bar</p>  <p>주문번호 04 : 410719 045 : 410718 05 : 41583-05 055 : 410712 07 : 410715 08 : 410711 09 : 410716</p>
<p>바리오노즐 (MV) 220bar H/L 0204008030(04) 직/분 0204008530(04)</p> 	<p>회전노즐 (MV) 255bar 주문번호 0204007300(02)</p> 	<p>터보노즐 (MV) 400bar/500bar 주문번호 0204006900(03)</p> 	<p>회전노즐 (PA) 250bar 주문번호 035 : 25162035 045 : 25162045 055 : 25162050</p> 	<p>터보노즐 (PA) 350bar 주문번호 25173540(04) 주문번호 25173545(045)</p> 
<p>터보노즐 (PA) 500bar 주문번호 25175040(04) 주문번호 25175045(045)</p> 	<p>대포노즐 (PA) 240bar 주문번호 80042023(09) 주문번호 80041823(07)</p> 	<p>트윈노즐 220bar 주문번호 PA:23000000(TD1) 주문번호 테코맥:470300(TD)</p> 	<p>삼중노즐 250bar 주문번호 25080045</p> 	<p>샌딩노즐 TS8 280bar 주문번호 25000015(045) 주문번호 25000012(03)</p> 

※ 다른 사양의 제품을 원하실 경우 문의 바랍니다.

※ 주문시 맨 뒤의 노즐표를 보고 주문하셔야 합니다. (사용 압력과 유량 정보가 필요함)

● Lance & Nozzle

<p>랜스+회전노즐 03 주문번호 410738</p> 	<p>랜스+회전노즐 045 주문번호 410725</p> 	<p>랜스+바리오노즐 03 주문번호 411562</p> 	<p>랜스+바리오노즐 045 주문번호 41156</p> 	<p>랜스+분사노즐 주문번호 123925(028)</p> 
---	--	--	---	---

● Lance (랜스)

<p>랜스 12CM 002020305 300(곡) 002020412 400(직,셀프) 40640 400(SUS)직 0020203012 700(곡,직) 40770000 900(곡) 002020136 900(직) 002020236</p> 	<p>랜스 1200(곡) 002020147 1200(직) 002020247 1500(곡) 40850000 1700(곡) 40870000 2000(곡) 40900000</p> 	<p>더블랜스 주문번호 41092800</p> 	<p>노즐캡 + with 1/4 소켓 주문번호 005850304</p> 
--	--	--	---

● Frame (차대)

<p>주문번호 44581SET</p> 	<p>주문번호 BODY-CPE-L</p> 	<p>주문번호 BODY-CP-SST</p> 	<p>주문번호 BODY-CPE-SST-M</p> 	<p>주문번호 BODY-CPE-BIG</p> 
--	--	---	---	--

※ 디자인은 사전 예고 없이 변경될 수 있습니다.

● Hose Reel (호스릴)

<p>자동호스릴 (스테인레스스틸) 30m : Mr30A-SUS-AUTO 40~50m : Mr50A-SUS-AUTO</p> 	<p>호스릴 차대부착용 (스테인레스스틸) 50A : R50B-SUS 100A : R100B-SUS</p> 	<p>호스릴 핸디형 (스테인레스스틸) 50A : R50A-SUS 100A : R100A-SUS</p> 	<p>호스릴 50A : R50A-ST 100A : R100A-ST 200A : R200A-ST</p> 
---	--	---	--

● Hose (호스)

<p>고압호스 1/4 * 1W 고압호스 1/4 * 2W 고압호스 3/8 * 2W</p> 	<p>파이프크리닝 호스 고압호스 1/8(외경 7.5mm) 고압호스 1/4(외경 12.2mm)</p> 	<p>파이프크리닝+노즐 SET 10M / 20M / 30M (410581) (410582) (410584)</p> 	<p>저압 스위블LR 26100000 스위블MR-KR 003010106 고압 스위블 MR-O 26105000 MR-1(SUS) 26106100</p> 
--	---	--	---

※ 다른 사양의 제품을 원하실 경우 문의 바랍니다.

● Connector (커넥터 부품)

건니뿔
3/8*M22
주문번호 003031306



연결니뿔
M22*M22
주문번호 003031122



육각속나사
1/4*M22
주문번호 003031204KC



속니뿔
1/4*M22 : 주문번호 003031204
3/8*M22 : 주문번호 003031206



양니뿔
1/4 : 주문번호 IT-04
3/8 : 주문번호 IBT-06



니뿔
3/8M*1/2M
주문번호 IT-06-08B



니뿔
1/8M*1/4M
주문번호 IT-02-04B



니뿔
1/2M*3/4M
주문번호 IT-08-12B



엘보
1/4M*3/8M : 주문번호 IBT9-06-04
1/8M*1/4M : 주문번호 IBT9-04-02



엘보
3/8M*3/8M
주문번호 IBT9-06



엘보
3/8M*3/8F
주문번호 5T9-06



엘보
1/8F*1/4M
주문번호 5T9-02-04B



티보
3/8F : 주문번호 T-3-8F-ST
3/4F : 주문번호 T-3-4F-ST



티보
1/2F
주문번호 T-12F-BR



소켓
1/2 : 주문번호 Z12
3/4 : 주문번호 Z34



※ 다른 사양의 제품을 원하실 경우 문의 바랍니다.

● Connector (커넥터 부품)

<p>M22 커플링 1/4, 3/8</p> 	<p>릴용 커플링 K 시리즈 주문번호 5NO-1-4-M14</p> 	<p>릴용 커플링 K2000 시리즈, K-1122TST 주문번호 48106</p> 	<p>릴용 커플링 Profi 시리즈 주문번호 134122</p> 
<p>엘보 물호스 1/2*19mm 주문번호 NIP-1-2-L19MM</p> 	<p>물호스 커플링 16mm 주문번호 410474</p> 	<p>물호스 커플링 3/4*19mm 주문번호 003994512</p> 	<p>붓싱 3/8M*1/4F 주문번호 5BT-04-06ST 3/4M*1/2F 주문번호 5BT-08-12ST 1/2M*3/8F 주문번호 5BT-06-08ST</p> 
<p>호스압착 PT 1/4*3/8</p> 	<p>호스압착 PT 1/4*1/4</p> 	<p>호스압착 PT 3/8*1/4</p> 	<p>호스압착 5번 커플링 1/4</p> 
<p>호스압착 5번 커플링 3/8</p> 	<p>호스압착 5번 커플링 3/8*1/4</p> 	<p>호스압착 4번 커플링 1/4, 3/8</p> 	<p>호스압착 90° 5번 커플링 3/8</p> 
<p>커플링 3/8*M22</p> 	<p>조립스위블 5번 3/8F*3/8M 주문번호 2TB-06</p> 	<p>볼 밸브 1/4 : 주문번호 BOLLVV-1-4 3/8 : 주문번호 BOLLVV-3-8</p> 	

※ 다른 사양의 제품을 원하실 경우 문의 바랍니다.

● Gauge (게이지)

<p>1/8" 300bar (B타입) 주문번호 006014030</p> 	<p>1/4" 400bar (B타입) 주문번호 006016340</p> 	<p>1/4" 400bar (A타입) 주문번호 006026340 [250bar] 006026325</p> 	<p>1/4" 1000bar (A타입) 주문번호 10001-4A</p> 
--	--	--	--

● Etc Accessory (기타 악세서리)

<p>감속기 B31: 24ϕ (주문 50007100) B31: 30ϕ (펌프축) (주문 50007130) B18: 25.4ϕ (펌프축) (주문 50000000)</p> 	<p>팬 모터 TM 주문번호 400267 크란을 주문번호 440726 (TH900) 송풍팬모터+알커버 (크란을) 448506</p> 	<p>맥동기 210bar/0.1ℓ 주문번호 29020005 210bar/0.35ℓ 주문번호 29020205</p> 	<p>연료펌프 + 솔밸브 TM : 220 V 주문번호 071N1263 TM : 24 V 주문번호 071N1263 크란을 < TH900, TH640 주문 440731 220 V < TH890, TH630 주문 44371</p> 
--	--	--	--

<p>로터리 스위치 TM : 1단 주문번호 100891 TM : 2단 주문번호 1003835</p> 	<p>온도센서하우징 PA : 주문번호 29026035</p> 	<p>회전브러시 (PA) 주문번호 29050000</p> 	<p>제터밸브 (진동밸브) AR : 주문번호 40236</p> 
--	--	---	---

<p>회전 스위블 주문번호 2511300</p> 	<p>스위치 GV2-ME20, 22, 32 주문번호 GV2ME20 주문번호 GV2ME22 주문번호 GV2ME32</p> 	<p>제어반 15HP/20HP : 주문번호 SW-CONTROL-15HP AUTO 15HP/20HP : 주문번호 SW-CONTROL-20HP-AUTO AUTO 7.5HP/10HP : 주문번호 SW-CONTROL-10HP-AUTO</p> 	<p>온도센서 크란을 : TH890 주문번호 44167 TH900 주문번호 44954 TM : 1단 주문번호 TR741 2단 주문번호 101021</p> 
---	---	--	--

<p>폼랜스 LS12 Red 2.1ϕ FOAMER 주문번호 25185171 Black 1.8ϕ FOAMER 주문번호 25185118</p> 	<p>폼랜스 LS10 주문번호 25186050</p> 	<p>원터치 커플링 (1/4, 3/8)</p> 	
--	--	---	--

A 3/8(SUS) ARS350 주문번호 26203551
A 1/4 ARS250 주문번호 26201661
A 3/8 ARS250 주문번호 26201561
A 3/8 ARS220 주문번호 26203561
A 3/8 AR31 주문번호 0121730070
A AR3 주문번호 21-016

B 3/8(SUS) ARS350 주문번호 26205000
B 3/8 ARS250 (M) 주문번호 26201000
B 3/8 ARS250 (F) 주문번호 26201010
B 1/4 ARS250 주문번호 26201020
B 3/8 ARS220 주문번호 26203000
B 3/8 AR31 주문번호 0212002010
B AR3 주문번호 003022104

※ 다른 사양의 제품을 원하실 경우 문의 바랍니다.

*주문시 모델명을 꼭 확인해 주세요. (아래 표 내용 중 숫자는 품번입니다.)

단상 고압호스릴



K1120	K-2000	P-series
40184	481001	438702

삼상 고압호스릴



Quadro, Therm
44152

세척기 케이스



K1122	K2160	K2195	Profi160	Profi195
490072	480022	480024	438011	438012

물탱크 Profi



물탱크 Profi
43860

바퀴



K1122, K-2000	P-series	Quadro, Therm
44538	43817	44017

바퀴 커버



K1122, K-2000	P-series	Quadro, Therm
46011	46509	44018

폼랜스



1 ℓ	2 ℓ	퀵커플링1 ℓ	퀵커플링2 ℓ
135301	135311	135303	135313

필터(단상) 냉온수 필터



필터(단상)	냉온수 필터
410462	133003

Therm 물탱크 필터



Therm 물탱크 필터
150383

세제 필터



세제 필터
15038

게이지



단상 (250bar)	삼상 (400bar)
15039	150394

오일게이지



← 오일 적정 보충선

K-2000series	Q-series, bully, P-series	Therm
48017	42623	42520

물호스 커플링



물호스 커플링
410474

슬러지 석션 유닛 (잔수처리기)



슬러지 석션 유닛	슬러지 석션 부착 유닛
41800	41802

물 비산방지 커버



물 비산방지 커버	물 비산방지 커버
41052	132600

회전브러시 (크란즐)



회전브러시
410501

언더바디랜스



언더바디랜스 40cm	언더바디랜스 100cm
410751	41075

파이프크리닝호스



10m	20m	30m
410581	410582	410584

라운드크리너 Short/Long



라운드크리너 Short	라운드크리너 Long
41855	41850

라운드크리너 SUS



라운드크리너 SUS
41860 (055) / 41861 (045)

※ 다른 사양의 제품을 원하실 경우 문의 바랍니다.

*주문시 모델명을 꼭 확인해 주세요. (아래 표 내용 중 숫자는 품번입니다.)

압력조절밸브 (구형)



압력조절밸브(구형)
43444

압력조절밸브 (신형)



압력조절밸브(신형)
40490

세라믹 피스톤



K1122	K2160	K2195	P-series	Q-series
49021	410321	42908	40455	40505

세라믹 스프링



K1122	Profi	단상	삼상
43040	40453	41033	40506

체크밸브 단상용



체크밸브 단상용
41748

체크밸브 삼상용



체크밸브 삼상용
400621

패킹 KIT



K1122	K2195	K2160, P-series	삼상
49053	42911	410491	40517

리데나(오일셀)



K1122	K2195	K2160, P-series	삼상
41631	42907	41031	400441

PR심 세트



PR심 세트
413005

리미트 스위치



리미트 스위치
15018

스위치 on/off



K1122	단상, 삼상	Q-series, bulky	Therm
43329	411116	42644	44835

스위치 커버 set



단상, 삼상, 냉온수용main	삼상냉온수 보일러
43453	411105

회전노즐부품



03	035	045	055
410961	410970	41097	410978

터보노즐부품



04	045	05	055
410969	410976	410966	410971

온도센서



구형(Them890)	신형(Them900)
44167	44954

과열방지센서



과열방지센서
44388

피스톤 하우징



K1122	K2160	K2195	P-series
43003	410202	42906	40471

오일 하우징(+케이스)



K1122	K-2000	P-series	삼상
44501	465302	404701	40501

트러스트 베어링 세트



K1050P	k 단상	P-series
49208	43486	40462

각도판



K1122	K2160	K2195	Profi160	Profi195
41028 -10.75	41028 -10.25	41028 -12	40473 -7.4	40473 -5.75

※ 다른 사양의 제품을 원하실 경우 문의 바랍니다.

*주문시 모델명을 꼭 확인해 주세요.

펌프헤드 (단상)



K1122	K2160	K2195	P-series
49020	42160	42163	404511

펌프헤드 (삼상)



펌프헤드 (삼상)
405035

캡볼트



단상	삼상
41714	42026

넌 리턴 밸브



넌 리턴 밸브
14122

오일투명창



오일투명창
420181

호스릴 엘보 커넥터



K1122	K2160, K2195	P-series
49014	48014	43824

이지 스타트



K1120K-2000, Q-series, TH-series	K1122, P-series
141131	490411

우끼



Q-series, P-series TH-series (신형)
Q-series, P-series TH-series (구형) TH-series (신형)
46250 462505 44025

콘덴서



35mf	40mf
411144	43035

오버로드



220V	380V 삼상	380V전용 12A
444010	44058	460401

마그네트



220V	380V
444000	460051

기판



220V	380V	아날로그 Therm
42564	42563	44302

보일러 PR심



보일러 PR
150111

플로우+안전밸브



플로우+안전밸브
14235

연료분사노즐



Them630, Them640 Them890, Them900
440771 44077

광센서



광센서
442561

송풍팬



송풍팬
44380

트랜스 포머 (점화)



트랜스포머(점화)
440742

점화플러그



점화플러그
44080

연료펌프+솔밸브



연료펌프+솔밸브
44371

※ 다른 사양의 제품을 원하실 경우 문의 바랍니다.

● 미스팅 펌프 - 야외 냉방 | 냄새중화 | 미세먼지 제거 | 가습기능(습도조절)

RC-M 시리즈	XM-M 시리즈	모델명	압력(bar)	토출량(L/min)	동력(hp)
		RC-M 01.10	100	1	0.26
		RC-M 02.10	100	2	0.52
		RC-M 03.10	100	3	0.78
		RC-M 04.10	100	4	1.05
		RC-M 05.10	100	5	1.31
		RC-M 06.10	100	6	1.57
		XM-M 02.10	100	2	0.5
		XM-M 08.10	100	8	2

모터+펌프	압력조절밸브	압력조절밸브	안전밸브	게이지
				

● 미스팅 노즐

CM-02SS	CM-03B	CM-04B
		
*내장 필터 있음	*내장 필터 없음	*내장 필터 있음



● 노즐 사양

구경(mm)	유량(L/m)	압력(Bar)	Thread No.
0.15	0.036 ~ 0.05	30 ~ 70	10/24unc/2A
0.20	0.05 ~ 0.08	30 ~ 70	10/24unc/2A
0.30	0.095 ~ 0.120	30 ~ 70	10/24unc/2A
0.40	0.14 ~ 0.20	30 ~ 70	10/24unc/2A
0.50	0.17 ~ 0.22	30 ~ 70	10/24unc/2A

※ 다른 사양의 제품을 원하실 경우 문의 바랍니다.

● AR 펌프 및 액세서리 - 농업 및 산업현장에서 고장없이 오래 사용할 수 있는 제품



<장점>

- 액체없이 구동가능
- 강한 흡입력 (펌프를 가동할때 내부에 액체를 가득 채우는) 기능
- 모든 기계적인 구동 부분들을 oil(오일) 윤활방식
- 사용 압력 범위는 0에서 50bar, 사용유량은 13에서 920ℓ 로 다양
- 펌프의 크기가 컴팩트
- 다양한 구동 방식을 선택하여 사용이 가능 : 540rpm의 트랙터 동력 인출장치, 감속기가
- 연결된 가솔린 엔진 및 벨트풀리로 연결된 전기모터, 유압식 모터 구동 및 12V 또는 24V 직구 등

<용도>

- 농약 분무용(과수원, 인삼밭, 골프장, 논과 밭), 수분공급용, 소독 및 방제
- ※ 트랙터, 차량, 비행기, 드론, SS기동기 설치 활용 가능



AR 30(C/SP)
32095
압력: 40bar
물량: 36,2L/min
동력: 2,9hp
흡입: Ø25
토출: Ø13



압력조절밸브
GI 40
900



AR 50 C/SP: 32098
SP: 32097
압력: 40bar
물량: 65,8L/min
동력: 5,2hp
흡입: Ø30
토출: Ø13



압력조절밸브
GI 40
900



AR 813 C/SP: 32107
C/C: 21106
C/F: 32108
압력: 50bar
물량: 79,9L/min
동력: 8,8hp
흡입: Ø40
토출: Ø3/4" G(M)



압력조절밸브
VDR 50
950



AR 1064 C/C: 32115
C/SP: 32116
압력: 50bar
물량: 108,5L/min
동력: 13,1hp
흡입: Ø40
토출: Ø3/4"



압력조절밸브
VDR 50
950

By Matic 50
960



AR 1203 C/C: 32118
C/SP: 32119
C/F: 32120
압력: 50bar
물량: 115,8L/min
동력: 13,6hp
흡입: Ø40
토출: Ø3/4" G(M)



압력조절밸브
VDR 50
950

By Matic 50
960



AR 1604 C/C: 32121
C/SP: 32122
압력: 50bar
물량: 153L/min
동력: 13,6hp
흡입: Ø40
토출: Ø3/4"



압력조절밸브
By Matic 50
960



BHA 150 C/C: 32127
C/F (축1+3/8ø): 32128
C/F (축32ø): 32129
압력: 50bar
물량: 142,6L/min
동력: 16,3hp
흡입: Ø40
토출: Ø3/4" G(M)



압력조절밸브
By Matic 50
960



BHA 200 C/C: 32133
C/F (축1+3/8ø): 32134
C/F (축32ø): 32135
압력: 50bar
물량: 193,7L/min
동력: 22,1hp
흡입: Ø40
토출: Ø3/4"



압력조절밸브
By Matic 50
960

※ 다른 사양의 제품을 원하실 경우 문의 바랍니다.

● AR 펌프 및 액세서리



AR 460BP
C/C 32055
압력: 20bar
물량: 450,3L/min
동력: 22,1hp
흡입: ϕ 70
토출: ϕ 40

압력조절밸브
GI 40
900



전기모터 펌프 어셈블리 AR 30 EM-ET
31964
모터: 220V 3hp
압력: 40bar
물량: 36,2L/min
흡입: ϕ 25
토출: ϕ 13



엔진 펌프 어셈블리 AR 30 S-SD HONDA
엔진: 6.5hp
압력: 40bar
물량: 36,2L/min
흡입: ϕ 25
토출: ϕ 13



● 축 방식

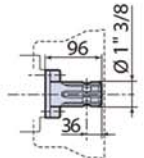

유니버설 샤프트 C/SP → C/C TYPE로 만들때

폴리(C/SP TYPE)

cod.1504 280 ϕ 2A (AR30)
cod.1495 310 ϕ 2A (AR30, AR50)
cod.1516 310 ϕ 3A (AR813, AR1064, AR1203)
cod.1520 310 ϕ 3A (AR1203 전용)
cod.1515 320 ϕ 4A (AR1203 전용)

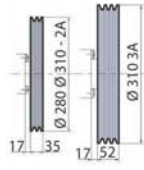
● 압력조절밸브

GR 40 40 / 80
880

펌프타입
AR303, AR403
AR503



GI 40 40 / 80
900

펌프타입
AR30, AR40
AR303, AR403
AR50
AR503



RM 40 40 / 80
903

펌프타입
AR30, AR40
AR50
AR503



※ 다른 사양의 제품을 원하실 경우 문의 바랍니다.

● 압력조절밸브

VDR 50
50 / 130
950

펌프타입
AR30, AR40
AR50
AR503
AR813
AR1203
AR1064



By Matic 50
50 / 200
905

펌프타입
AR1203
AR1064
AR1604
BHA



● 감속기

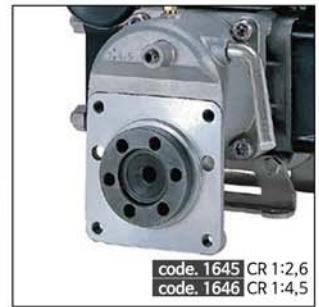

● 악세서리

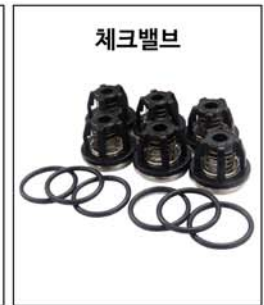
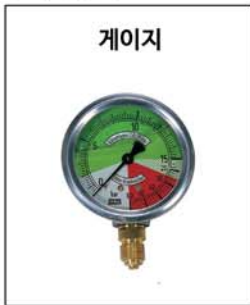

● AR 펌프 사용 용도



잡초 제거 및 농약살포



과수원, 포도밭 농약살포



골프장 관리차



가로수 방제



소방 방제



차량 소독기

※ 다른 사양의 제품을 원하실 경우 문의 바랍니다.



※ 다른 사양의 제품을 원하실 경우 문의 바랍니다.

현장 사례



Nozzle - Chart

노즐번호 φ = mm 입력(bar)	토출량 (ℓ/min)																																			
	005	01	014	018	02	025	03	04	045	05	055	06	065	07	075	08	085	09	10	11	12	13	14	15	16	18	20	25	30	35	40	50	60	70	80	90
50	0.8	1.6	2.2	2.8	3.2	4.0	4.7	6.3	7.1	7.9	8.7	9.5	10.3	11.1	11.9	12.6	13.4	14.2	15.8	17.4	19.0	20.6	22.1	23.7	25.3	28.5	31.6	39.5	47.4	55.3	63.2	79.1	94.9	111	126	142
80	1.0	2.0	2.8	3.6	4.0	5.0	6.0	8.0	9.0	10.0	11.0	12.0	13.0	14.0	15.0	16.0	17.0	18.0	20.0	22.0	24.0	26.0	28.0	30.0	32.0	36.0	40.0	50.0	60.0	70.0	80.0	100	120	140	160	180
100	1.1	2.2	3.1	4.0	4.5	5.6	6.7	8.9	10.1	11.2	12.3	13.4	14.5	15.7	16.8	17.9	19.0	20.1	22.4	24.6	26.8	29.1	31.3	33.5	35.8	40.2	44.7	55.9	67.1	78.3	89.4	112	134	157	179	201
120	1.2	2.4	3.4	4.4	4.9	6.1	7.3	9.8	11.0	12.2	13.5	14.7	15.9	17.1	18.4	19.6	20.8	22.0	24.5	26.9	29.4	31.8	34.3	36.7	39.2	44.1	49.0	61.2	73.5	85.7	98.0	122	147	171	196	220
140	1.3	2.6	3.7	4.8	5.3	6.6	7.9	10.6	11.9	13.2	14.6	15.9	17.2	18.5	19.8	21.2	22.5	23.8	26.5	29.1	31.7	34.4	37.0	39.7	42.3	47.6	52.9	66.1	79.4	92.6	106	132	159	185	212	238
150	1.4	2.7	3.8	4.9	5.5	6.8	8.2	11.0	12.3	13.7	15.1	16.4	17.8	19.2	20.5	21.9	23.3	24.6	27.4	30.1	32.9	35.6	38.3	41.1	43.8	49.3	54.8	68.2	82.2	95.9	110	137	164	192	219	246
160	1.4	2.8	4.0	5.1	5.7	7.1	8.5	11.3	12.7	14.1	15.6	17.0	18.4	19.8	21.2	22.6	24.0	25.5	28.3	31.1	33.9	36.8	39.6	42.4	45.3	50.9	56.6	70.7	84.9	99.0	113	141	170	198	226	255
180	1.5	3.0	4.2	5.4	6.0	7.5	9.0	12.0	13.5	15.0	16.5	18.0	19.5	21.0	22.5	24.0	25.5	27.0	30.0	33.0	36.0	39.0	42.0	45.0	48.0	54.0	60.0	75.0	90.0	105	120	150	180	210	240	270
200	1.6	3.2	4.4	5.7	6.3	7.9	9.5	12.6	14.2	15.8	17.4	19.0	20.6	22.1	23.7	25.3	26.9	28.5	31.6	34.8	37.9	41.1	44.3	47.4	50.6	56.9	63.2	79.1	94.9	111	126	158	190	221	253	285
220	1.7	3.2	4.6	6.0	6.6	8.3	9.9	13.3	14.9	16.6	18.2	19.9	21.6	23.2	24.9	26.5	28.2	29.8	33.2	36.5	39.8	43.1	46.4	49.7	53.1	59.7	66.3	82.9	99.5	116	133	166	199	232	265	298
240	1.7	3.5	4.8	6.2	6.9	8.7	10.4	13.9	15.6	17.3	19.1	20.8	22.5	24.2	26.0	27.7	29.4	31.2	34.6	38.1	41.6	45.0	48.5	52.0	55.4	62.4	69.3	86.6	104	121	139	173	208	242	277	312
260	1.8	3.6	5.0	6.5	7.2	9.0	10.8	14.4	16.2	18.0	19.8	21.6	23.4	25.2	27.0	28.8	30.6	32.4	36.1	39.7	43.3	46.9	50.5	54.1	57.7	64.9	72.1	90.1	108	126	144	180	216	252	288	324
280	1.9	3.7	5.2	6.7	7.5	9.4	11.2	15.0	16.8	18.7	20.6	22.4	24.3	26.2	28.1	29.9	31.8	33.7	37.4	41.2	44.9	48.6	52.4	56.1	59.9	67.3	74.8	93.5	112	131	150	187	224	262	299	337
300	1.9	3.9	5.4	7.0	7.7	9.7	11.6	15.5	17.4	19.4	21.3	23.2	25.2	27.1	29.0	31.0	32.9	34.9	38.7	42.6	46.5	50.3	54.2	58.1	62.0	69.7	77.5	96.6	116	136	155	194	232	271	310	349
350	2.1	4.2	5.9	7.5	8.4	10.5	12.5	16.7	18.8	20.9	23.0	25.1	27.2	29.3	31.4	33.5	35.6	37.6	41.8	46.0	50.2	54.4	58.6	62.7	66.9	75.3	83.7	105	125	146	167	199	251	293	335	376
400	2.2	4.5	6.3	8.0	8.9	11.2	13.4	17.9	20.1	22.4	24.6	26.8	29.1	31.3	33.5	35.8	38.0	40.2	44.7	49.2	53.7	58.1	62.6	67.1	71.6	80.5	89.4	112	134	157	179	224	268	313	358	402
450	2.4	4.7	6.6	8.5	9.5	11.9	14.2	19.0	21.3	23.7	26.1	28.5	30.8	33.2	35.6	37.9	40.3	42.7	47.4	52.2	56.9	61.7	66.4	71.2	75.9	85.4	94.9	119	142	166	190	237	285	332	379	427
500	2.5	5.0	7.0	9.0	10.0	12.5	15.0	20.0	22.5	25.0	27.5	30.0	32.5	35.0	37.5	40.0	42.5	45.0	50.0	55.0	60.0	65.0	70.0	75.0	80.0	90.0	100	125	150	175	200	250	300	350	400	450
550	2.6	5.2	7.3	9.4	10.5	13.1	15.7	21.0	23.6	26.2	28.8	31.5	34.1	36.7	39.3	42.0	44.6	47.2	52.4	57.7	62.9	68.2	73.4	78.7	83.9	94.4	105	131	157	184	210	262	315	367	420	472
600	2.7	5.5	7.7	9.9	11.0	13.7	16.4	21.9	24.6	27.4	30.1	32.9	35.6	38.3	41.1	43.8	46.6	49.3	54.8	60.2	65.7	71.2	76.7	82.2	87.6	98.6	110	137	164	192	219	274	329	383	438	493
650	2.9	5.7	8.0	10.3	11.4	14.3	17.1	22.8	25.7	28.5	31.4	34.2	37.1	39.9	42.8	45.6	48.5	51.3	57.0	62.7	68.4	74.1	79.8	85.5	91.2	103	114	143	171	200	228	285	342	399	456	513
700	3.0	5.9	8.3	10.6	11.8	14.8	17.7	23.7	26.6	29.6	32.5	35.5	38.5	41.4	44.4	47.3	50.3	53.2	59.2	65.1	71.0	76.9	82.8	88.7	94.7	106	118	148	177	207	237	296	355	414	473	532
750	3.1	6.1	8.6	11.0	12.2	15.3	18.4	24.5	27.6	30.6	33.7	36.7	39.8	42.9	45.9	49.0	52.1	55.1	61.2	67.4	73.5	79.6	85.7	91.9	98.0	110	122	153	184	214	245	306	367	429	490	551
800	3.2	6.3	8.9	11.4	12.6	15.8	19.0	25.3	28.5	31.6	34.8	37.9	41.1	44.3	47.4	50.6	53.8	56.9	63.2	69.6	75.9	82.2	88.5	94.9	101	114	126	158	190	221	253	316	379	443	506	569
850	3.3	6.5	9.1	11.7	13.0	16.3	19.6	26.1	29.3	32.6	35.9	39.1	42.4	45.6	48.9	52.2	55.4	58.7	65.2	71.7	78.2	84.7	91.3	97.8	104	117	130	163	196	228	261	326	391	456	522	587
900	3.4	6.7	9.4	12.1	13.4	16.8	20.1	26.8	30.2	33.5	36.9	40.2	43.6	47.0	50.3	53.7	57.0	60.4	67.1	73.8	80.5	87.2	93.9	101	107	121	134	168	201	235	268	335	402	470	537	604
950	3.4	6.9	9.6	12.4	13.8	17.2	20.7	27.6	31.0	34.5	37.9	41.4	44.8	48.2	51.7	55.1	58.6	62.0	68.9	75.8	82.7	89.6	96.5	103	110	124	138	172	207	241	276	345	414	482	551	620
1000	3.5	7.1	9.9	12.7	14.1	17.7	21.2	28.3	31.8	35.4	38.9	42.4	46.0	49.5	53.0	56.6	60.1	63.6	70.7	77.8	84.9	91.9	99.0	106	113	127	141	177	212	247	283	354	424	495	566	636
1050	3.6	7.2	10.1	13.0	14.5	18.1	21.7	29.0	32.6	36.2	39.9	43.5	47.1	50.7	54.3	58.0	61.6	65.2	72.5	79.7	86.9	94.2	101	109	116	130	145	181	217	254	290	362	435	507	580	652
1100	3.7	7.4	10.4	13.3	14.8	18.5	22.2	29.7	33.4	37.1	40.8	44.5	48.2	51.9	55.6	59.3	63.0	66.7	74.2	81.6	89.0	96.4	104	111	119	133	148	185	222	260	297	371	445	519	593	667
1150	3.8	7.6	10.6	13.6	15.2	19.0	22.7	30.3	34.1	37.9	41.7	45.5	49.3	53.1	56.9	60.7	64.5	68.2	75.8	83.4	91.0	98.6	106	114	121	136	152	190	227	265	303	379	455	531	607	682
1200	3.9	7.7	10.8	13.9	15.5	19.4	23.2	31.0	34.9	38.7	42.6	46.5	50.3	54.2	58.1	62.0	65.8	69.7	77.5	85.2	93.0	101	108	116	124	139	155	194	232	271	310	387	465	542	620	697

Field 1

Field 2

Field 3

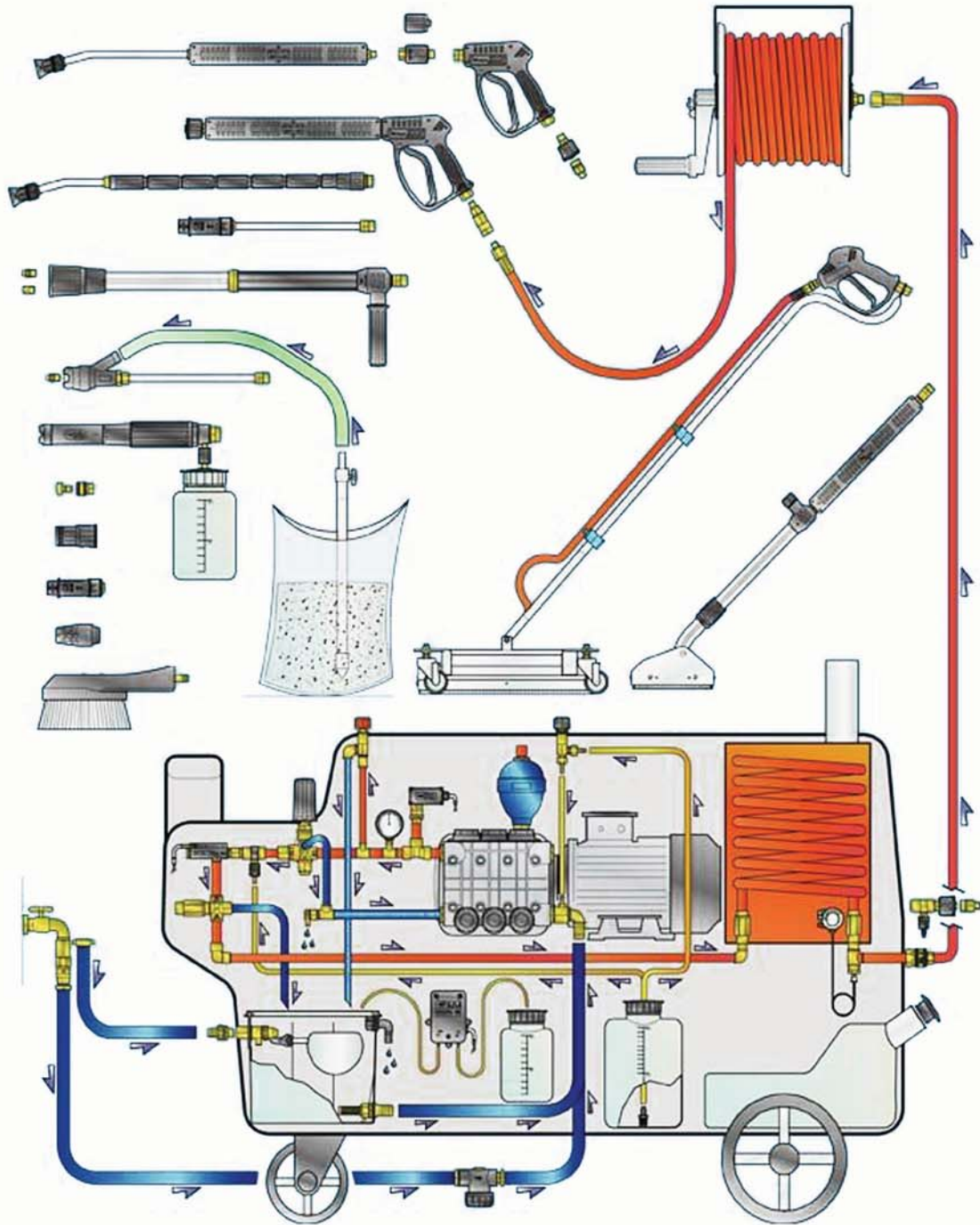

경기도 성남시 중원구 순환로 187 (상대원동)
 Tel. 1600-5335 / 031-743-5336
 Fax. 031-743-5336 E-mail. info@clean.co.kr

- 이노비즈기업
- ISO 9001 인증
- 부품소재 전문기업
- ISO 14001 인증
- 벤처기업 인증
- 생산물 배상 책임 보험 3억 가입

냉·온수 고압세척기 / 엔진 고압세척기 / 고압펌프 / 콜미스트 / 약세사리 / 셀프세차 약세사리 / 건·습식 바닥청소기

